

250**LEX** PUBLIC ART PROJECT

CONCEPT PROPOSAL
MAY 29, 2024

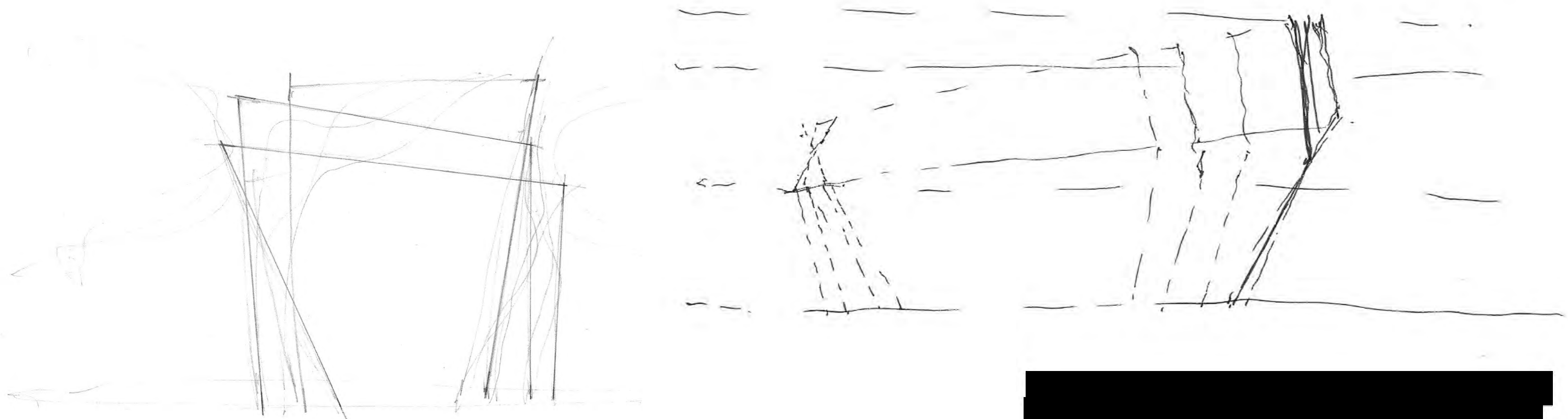

ARCHITECTURE + DESIGN

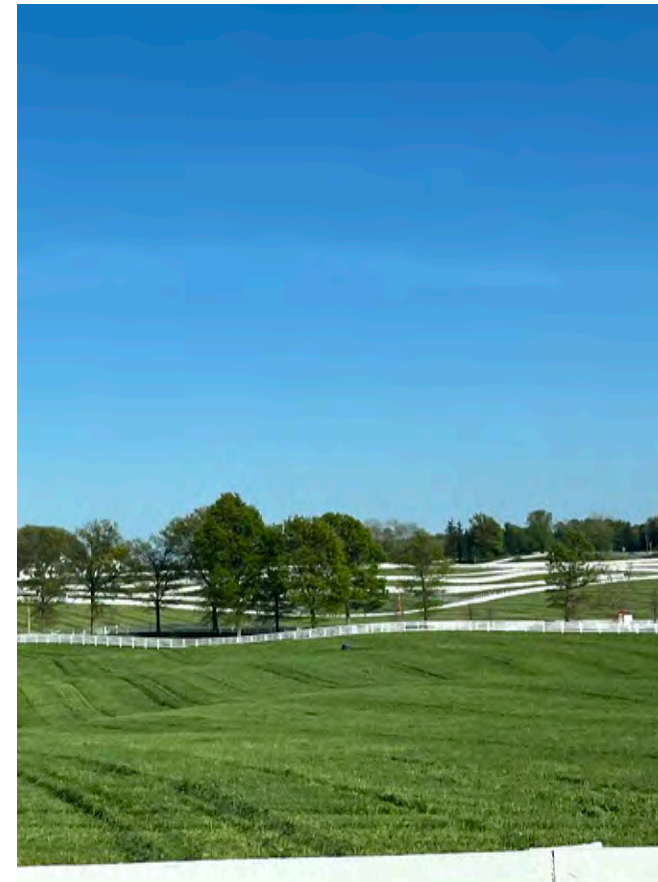

Historic Lexington

Lexington's history tracks in close parallel the post-Revolutionary War history of the United States. For both, there are many achievements to commemorate from the last 250 years. They include successful agricultural production, top quality bourbon, a strong intellectual base coming out of local universities along with thoroughbred horse breeding and well known basketball prowess. These achievements should all be celebrated as you look to the next 250 years ahead. We also note, as with the rest of the United States, Lexington's history includes moments which won't be celebrated, but should be recognized as important contributors to what Lexington is today. These include the displacement of indigenous peoples along with their cultures and practices; economic growth dependent on slave labor and the often violent silencing and forcing into the closet of loving relationships between same sex couples.

Lexington has already begun the process of acknowledging how varied and deep its history is and filling in the gaps in the dominant narrative currently written. We see this in public space with the widening of the subjects of the historical markers in recent years. The historical markers had been heavily weighted towards the era of European settlement and the celebration of military conquests. Markers more recently installed include contributions from African Americans and members of Lexington's LGBTQ+ community.

My inspiration for the artwork came from these historical markers. A community decides how it wants to be represented by the historical markers that it chooses to sponsor. The markers represent what is important to Lexington's citizenry and how they want to be seen.

How can we recognize the 250th year of Lexington's naming while acknowledging the layers of historical information rooted in community so that it extends the conversation to what Lexington wants to be in the future?

This new artwork will be your opportunity to make a new mark. It represents how you want to be recognized. It represents the history that you want to celebrate as you move into the future. It starts with historical markers culled from the hundreds of markers in the database and is layered with the unknown, unmarked histories that have been 'lost to us'. Both systems work together to represent how the past shapes the current conversation and how the present moment is a messy amalgamation of dominant stories and the silences that live alongside them.



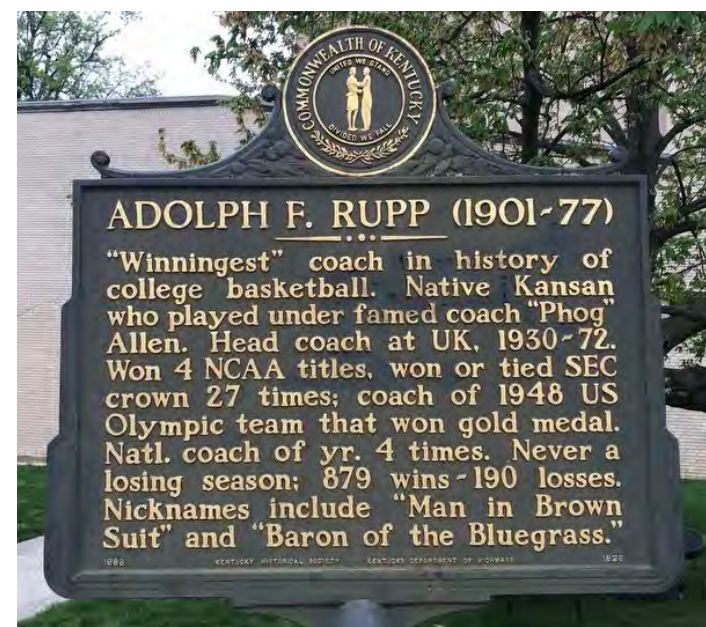
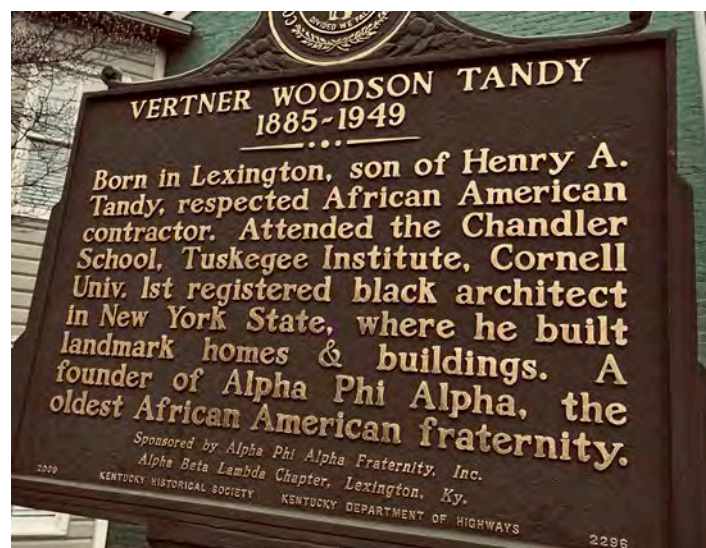
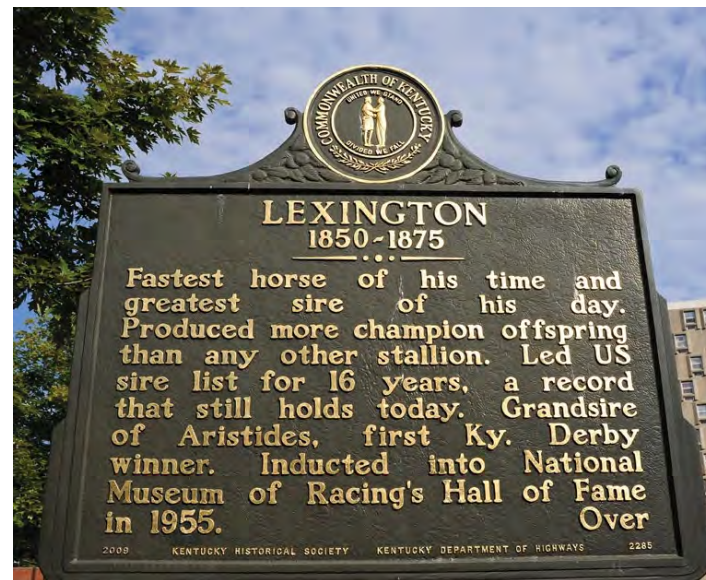
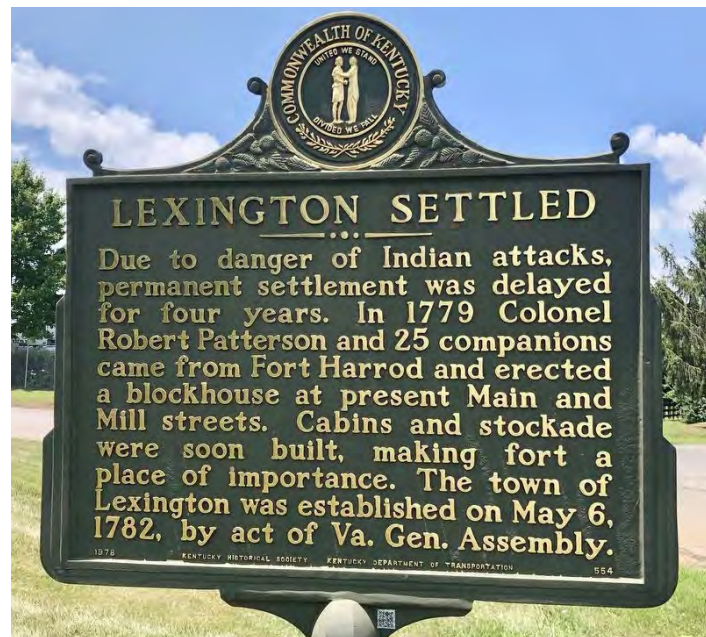
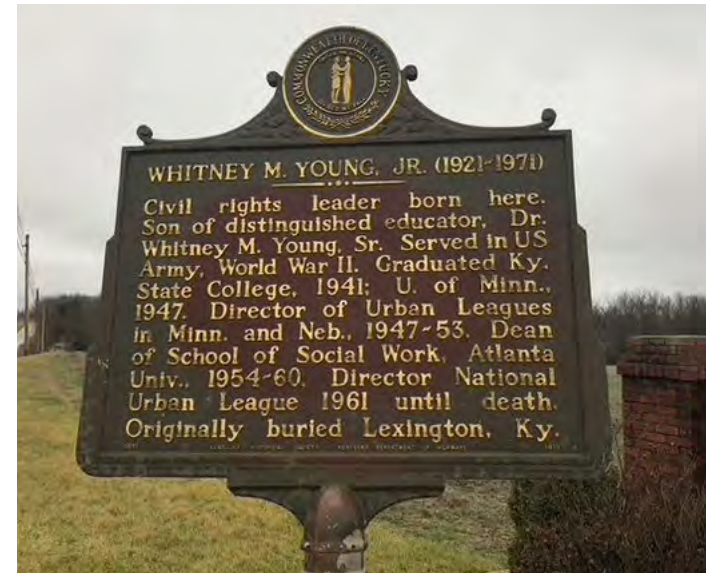
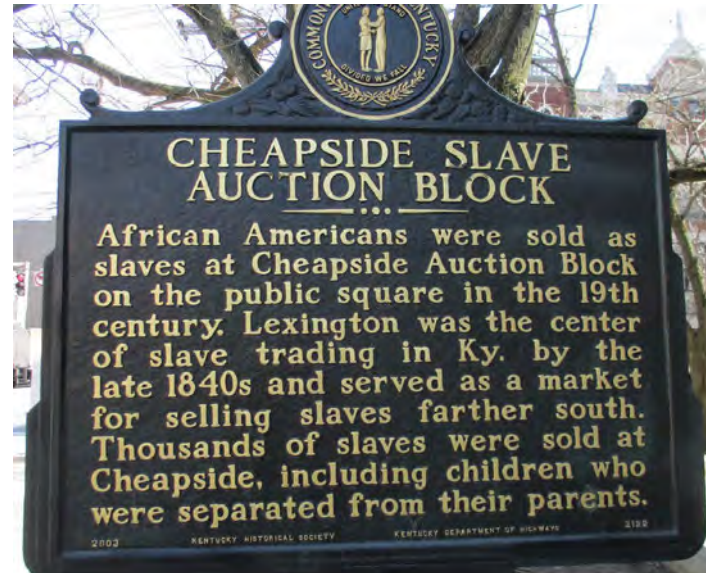

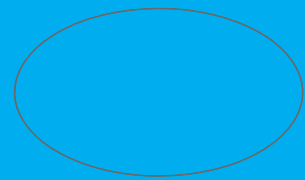

circle

interconnectivity of natural world
sun, moon and earth
past, present and future
continuous without beginning or end
space of ritual and healing

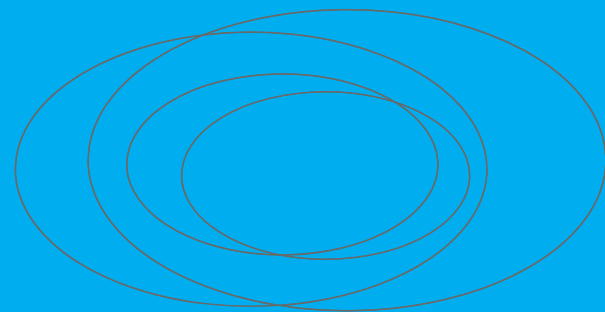

interconnected circles

circles shift and overlap with
varying centers.

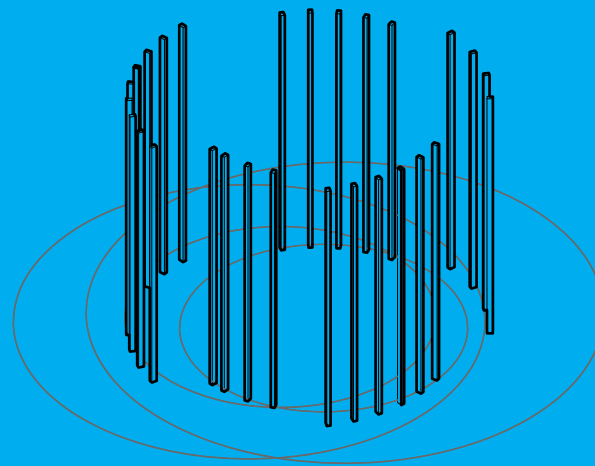

historical markers added

mapped onto circles
continuous interconnectivity of historical
moments

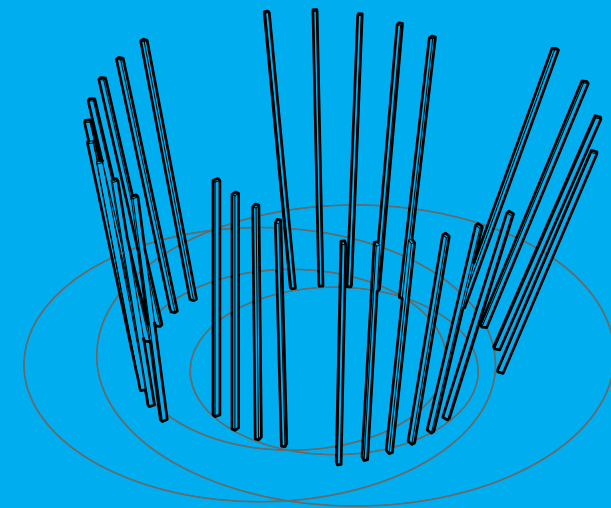

lean back - open up



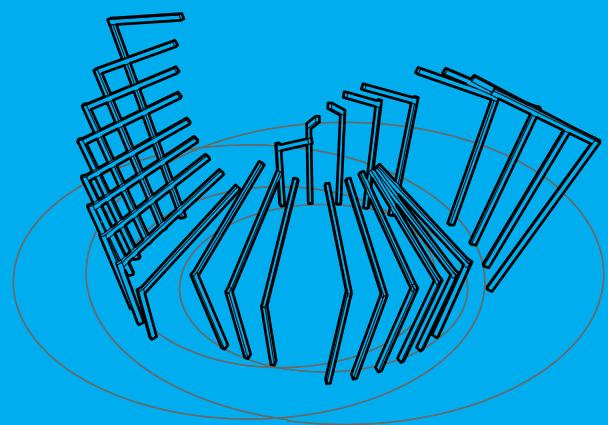

lean back - open up
reach back in again
holds like a vessel

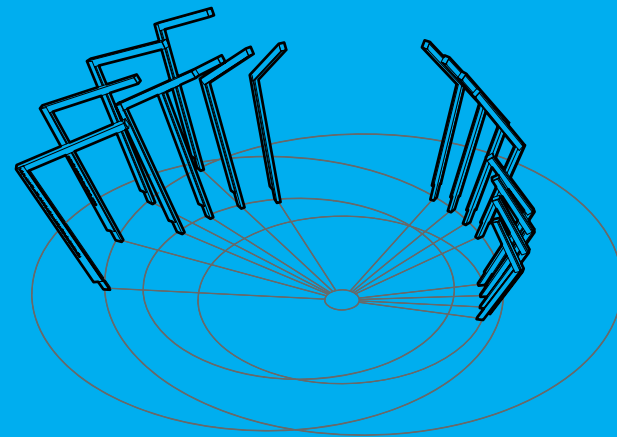

open the circle
open to seating on the site
open to multiple ways of
connecting
open to encourage movement in
and through

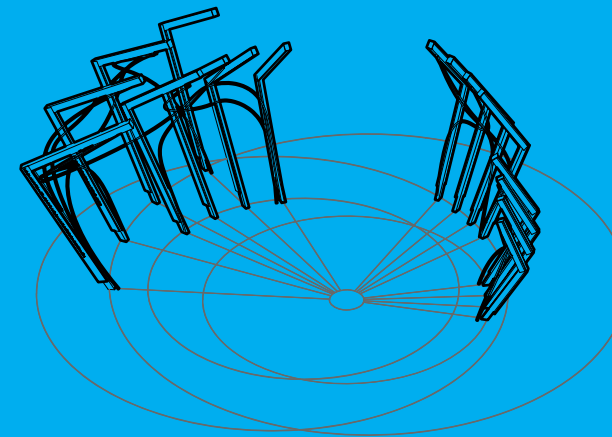

counter-narrative/alternative narrative
markers representing the collective
memory of those whose stories
have been erased move across the
historic markers according to their own
trajectory

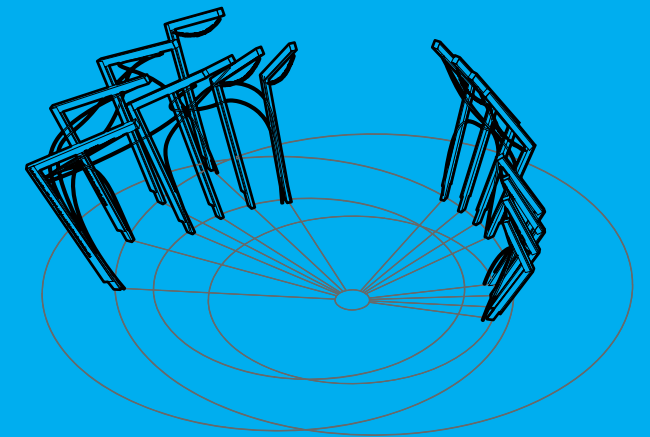

community stories
a third system of community stories is
added both in audio stories accessible
via QR code and in strings of rope
knottings created during story sharing
sessions.



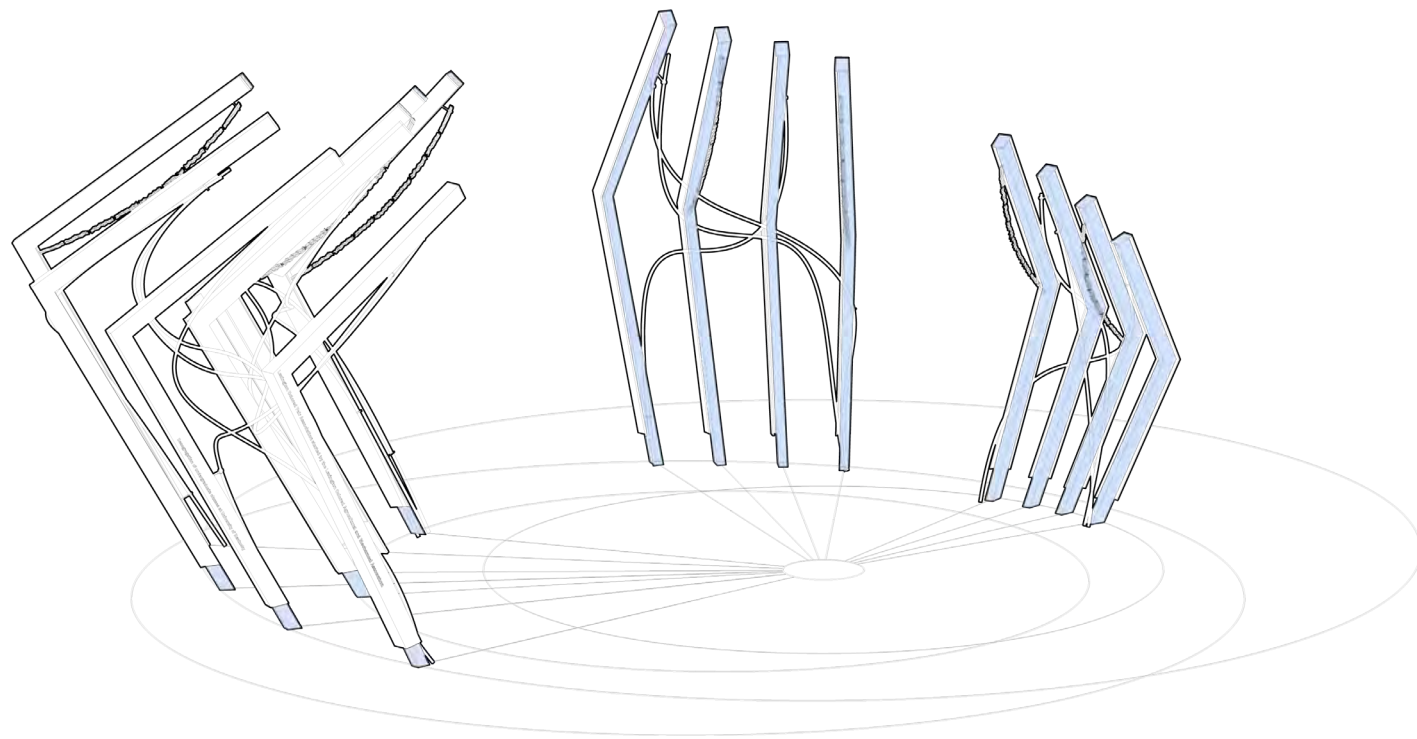

**painted steel markers
along stainless steel inlays circles
at ground**

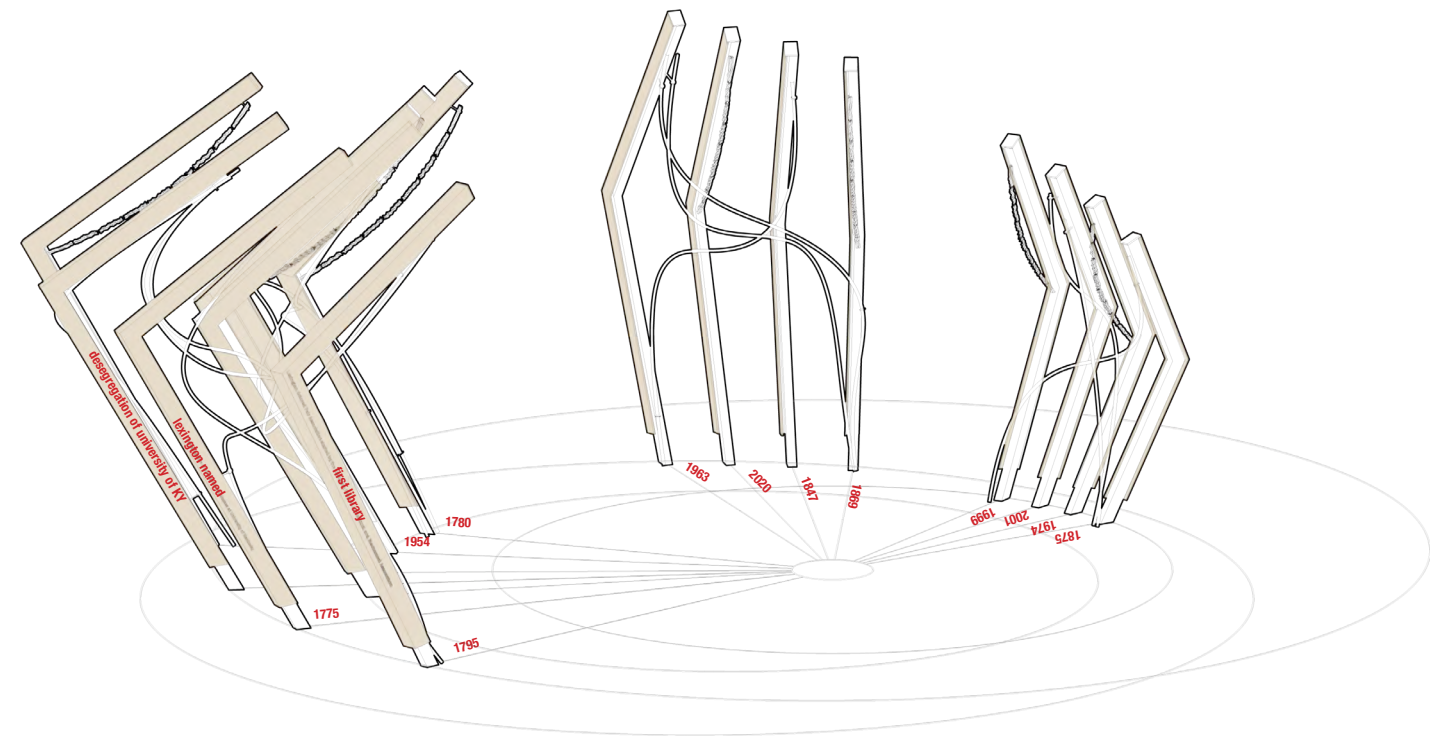

**exterior grade wood at two sides of
markers with engraved historical text
corresponding to dates at ground**

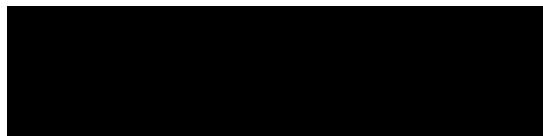

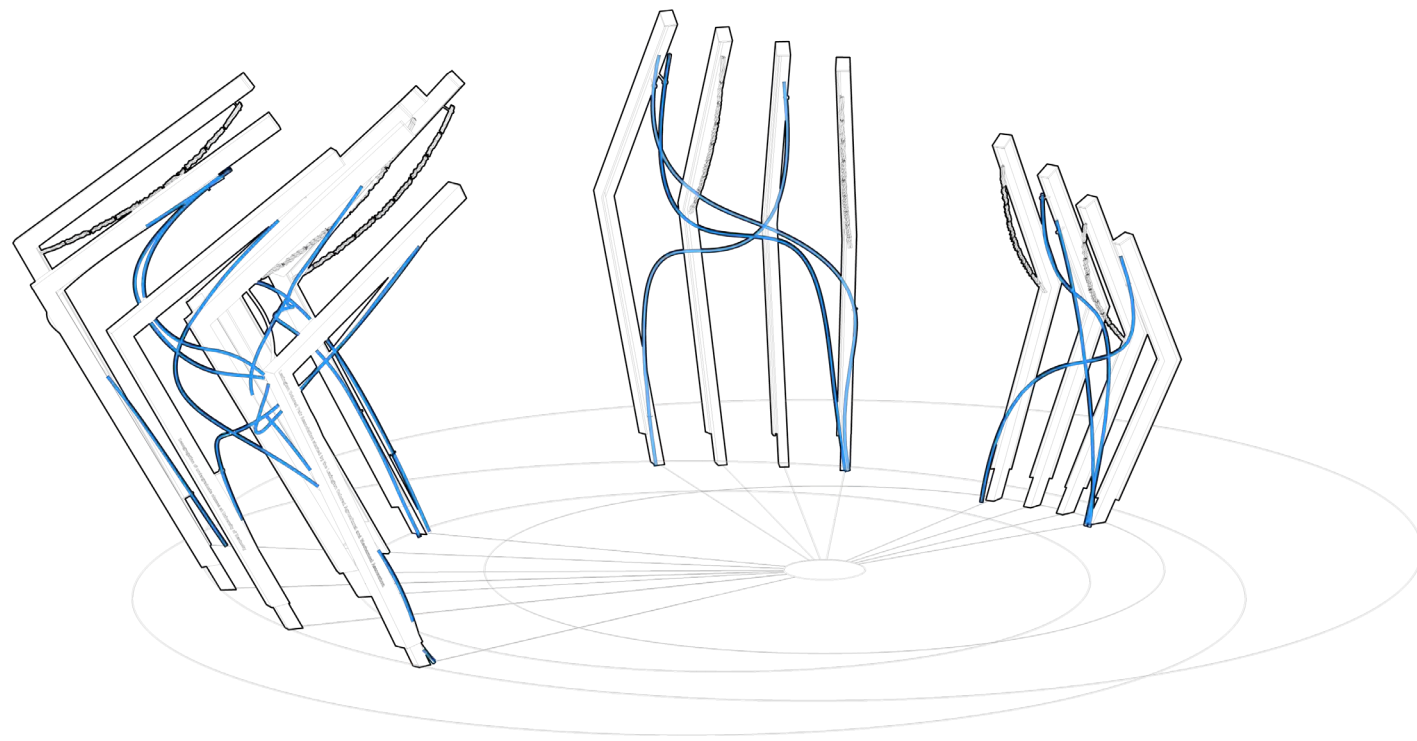

**painted steel rods move across
markers organically**

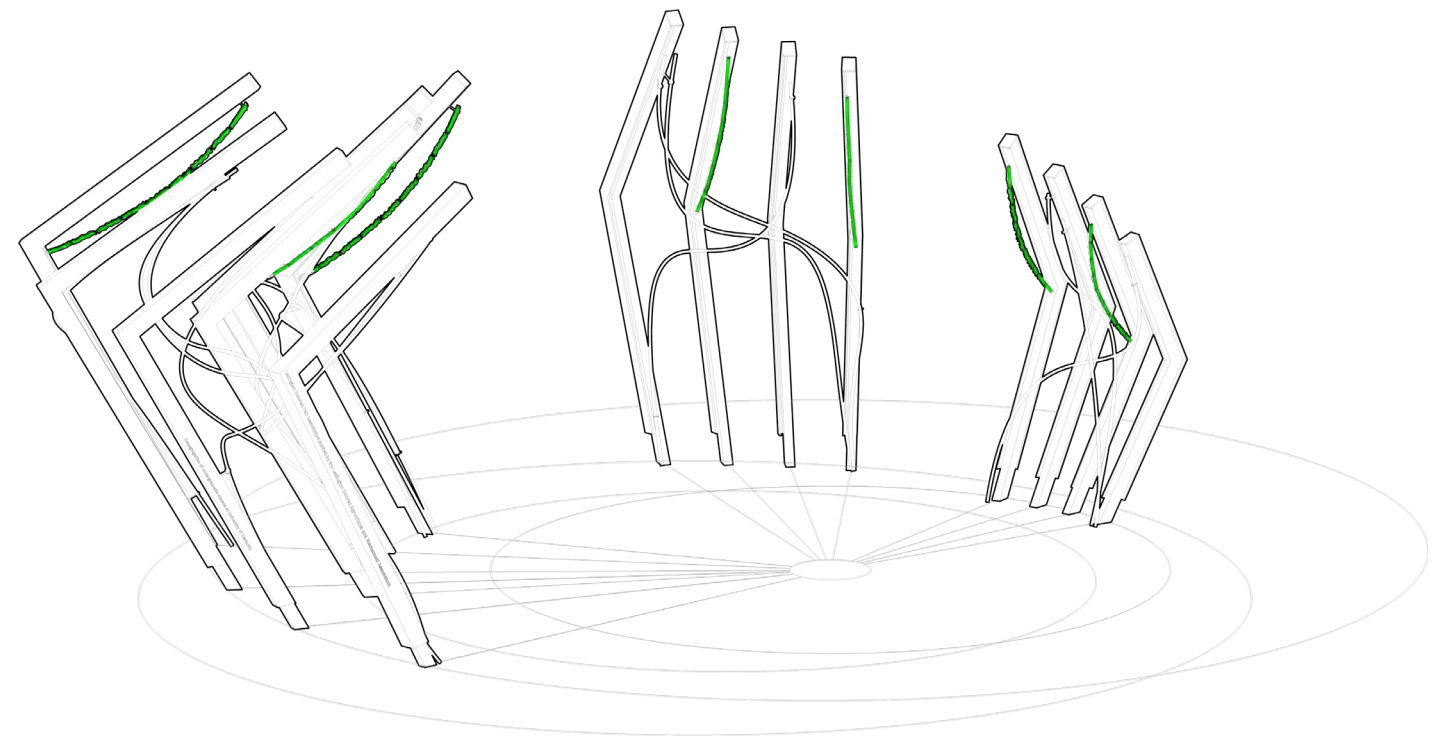

**collectively woven rope added to
markers**

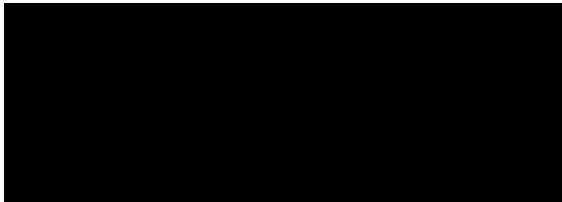

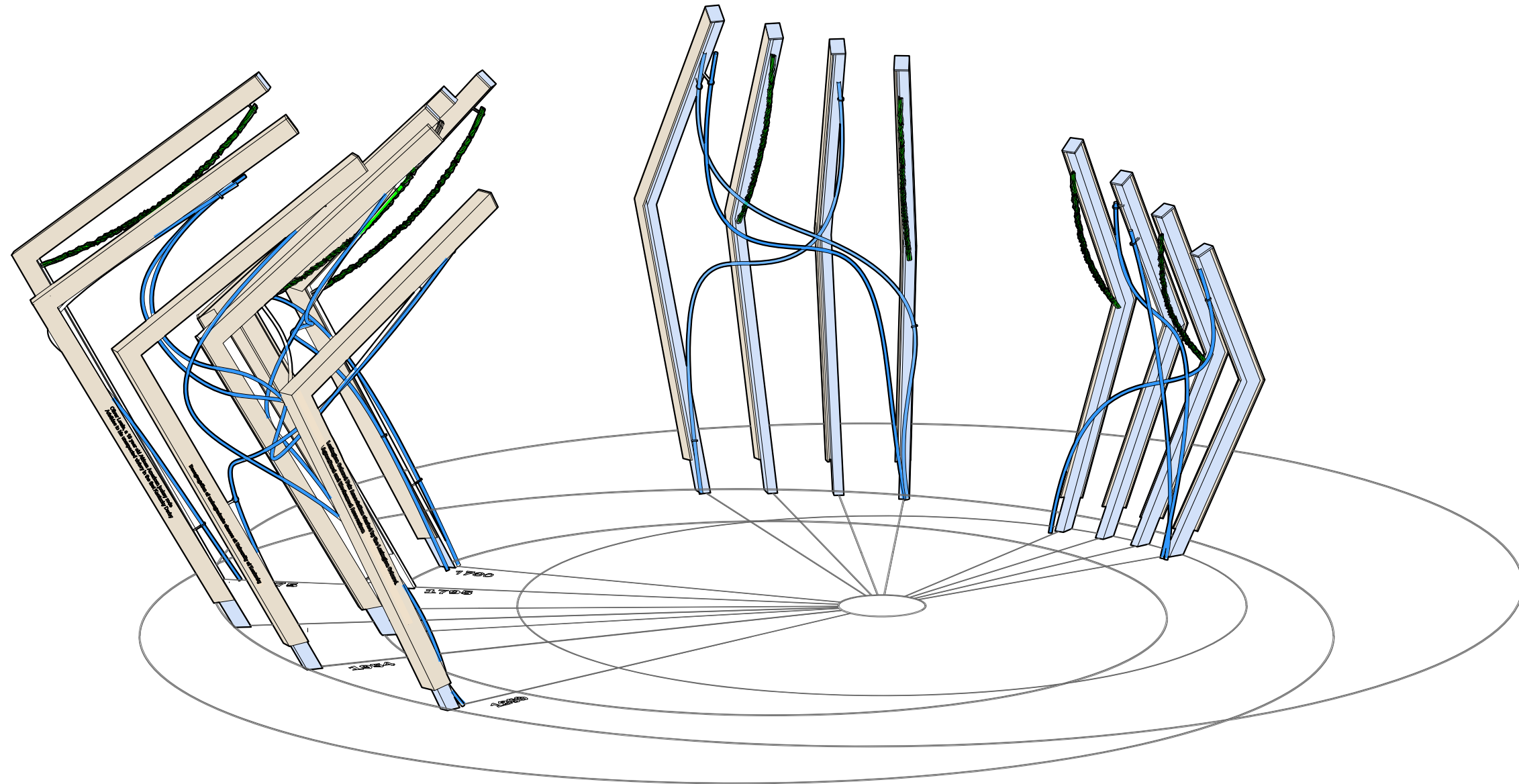

**dominant historical narrative, erased
histories and collective memories
exist together**

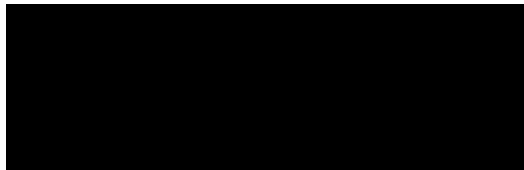

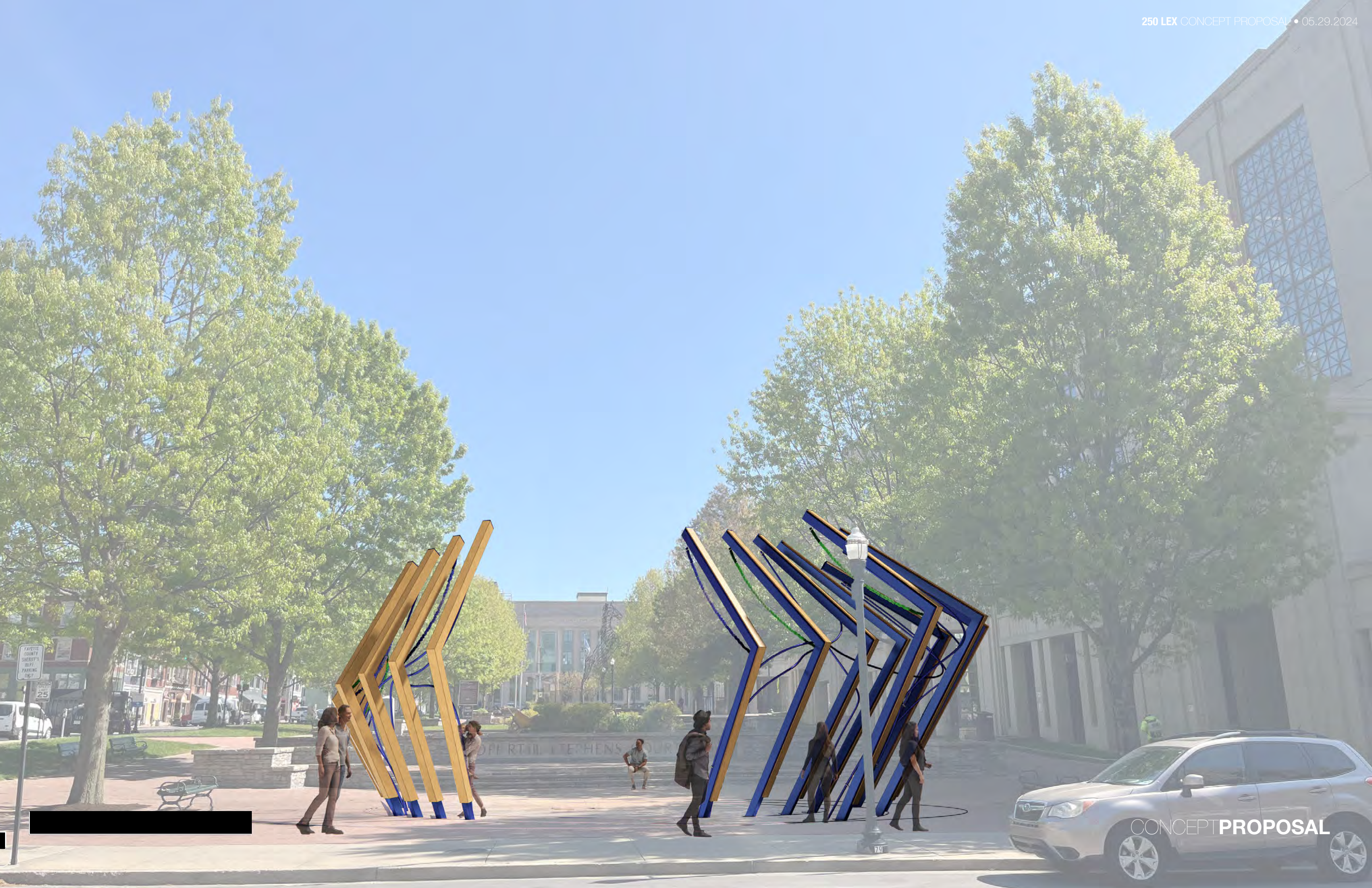

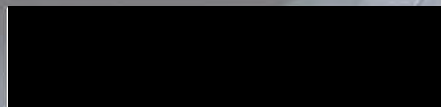



Lexington Colored Fair Association started by the Lexington Colored Agricultural and Mechanical Association

From 1865 to 1870, the Lexington Colored Agricultural and Mechanical Association held annual fairs to raise money for the education of African American children in Lexington, Kentucky.

Development of independent classes at University of Kentucky

From 1865 to 1870, the Lexington Colored Agricultural and Mechanical Association held annual fairs to raise money for the education of African American children in Lexington, Kentucky.

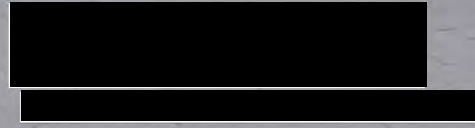

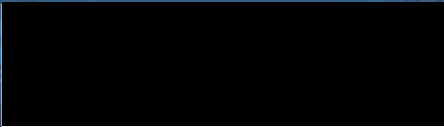

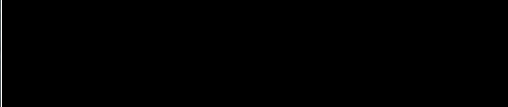

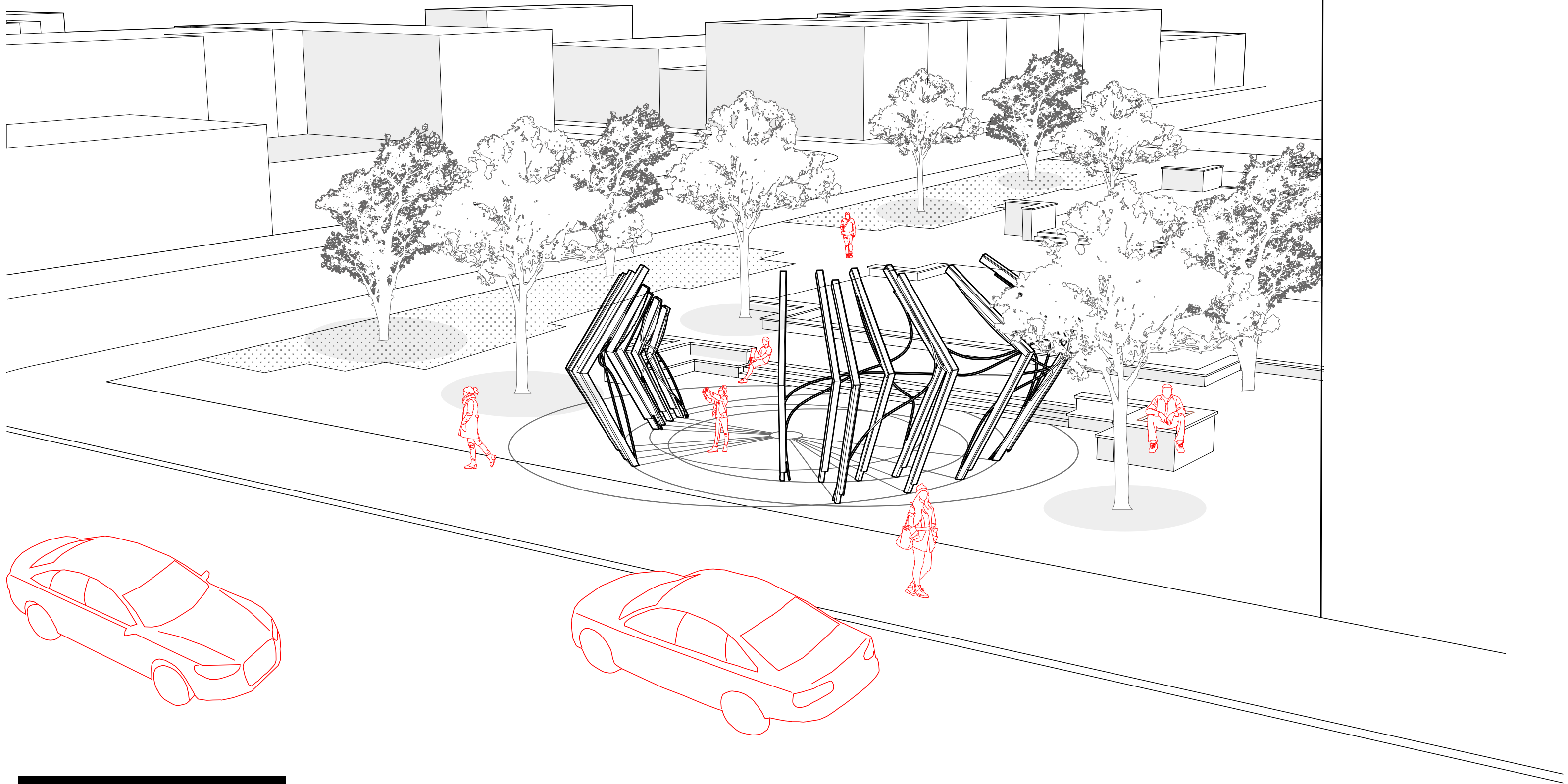

weekday in the city

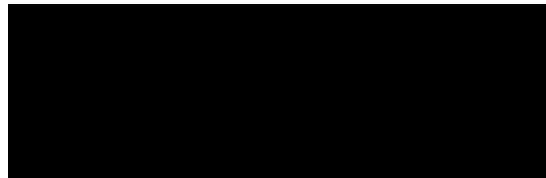

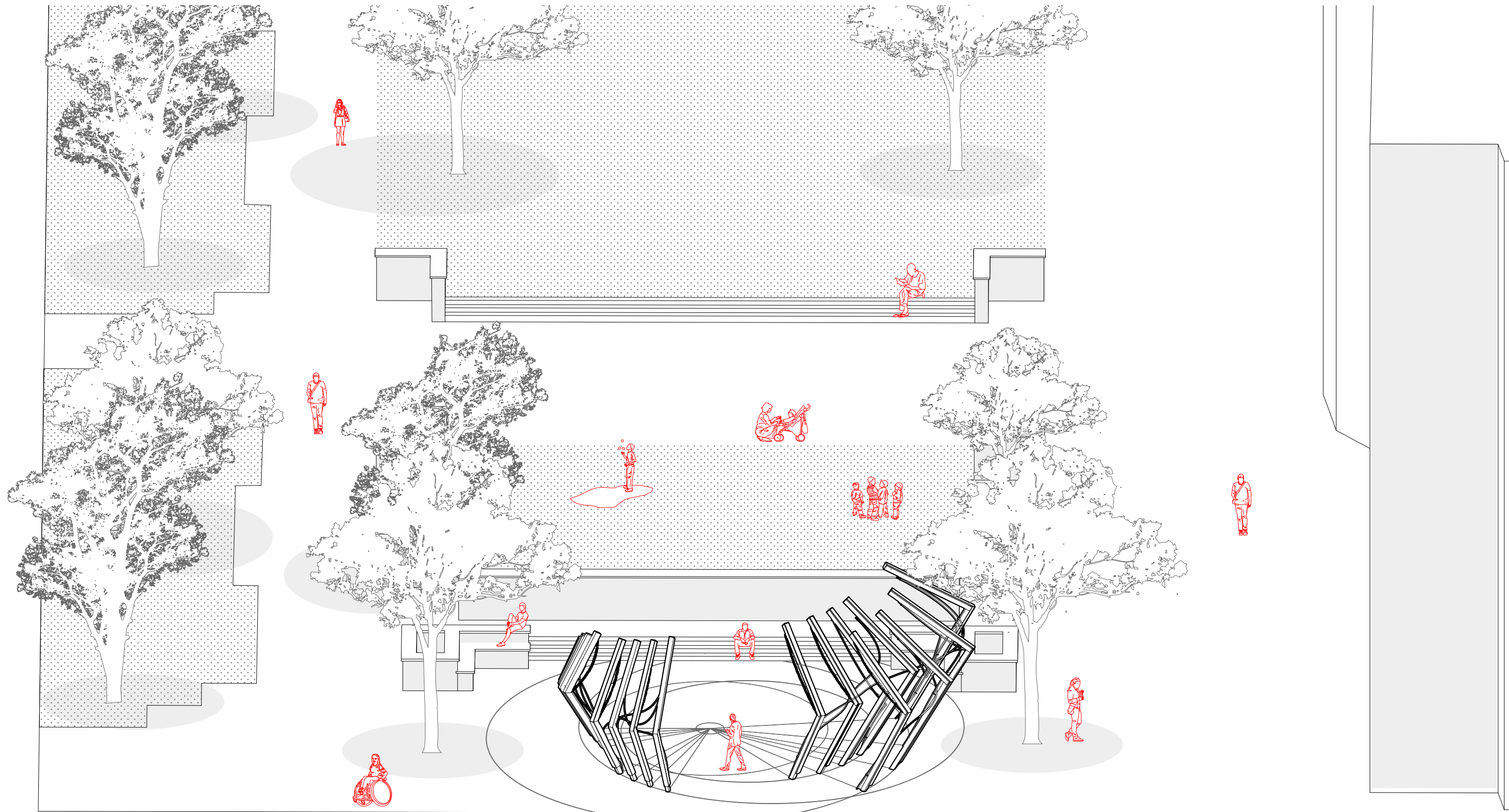

weekend in the park

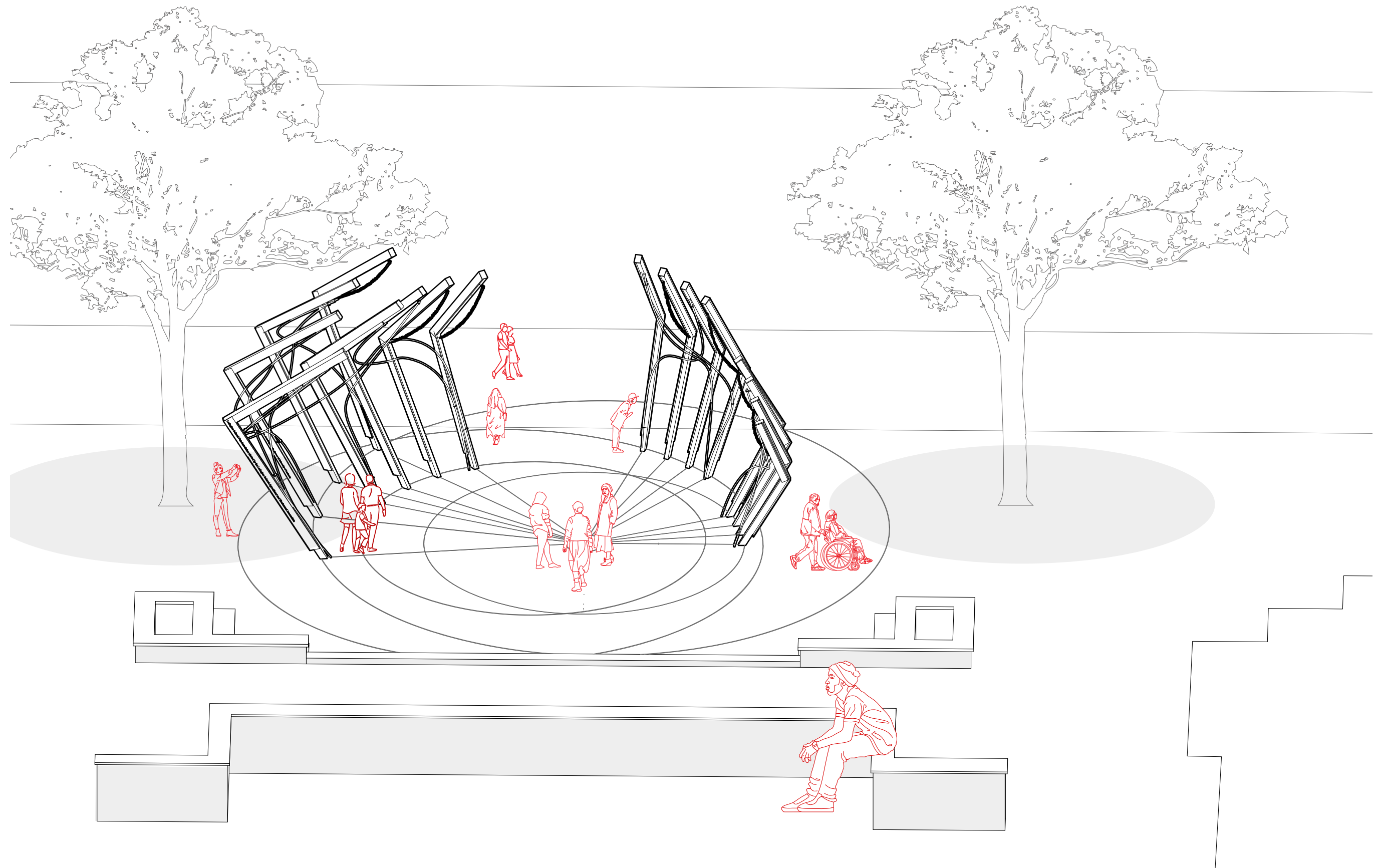

gathering within

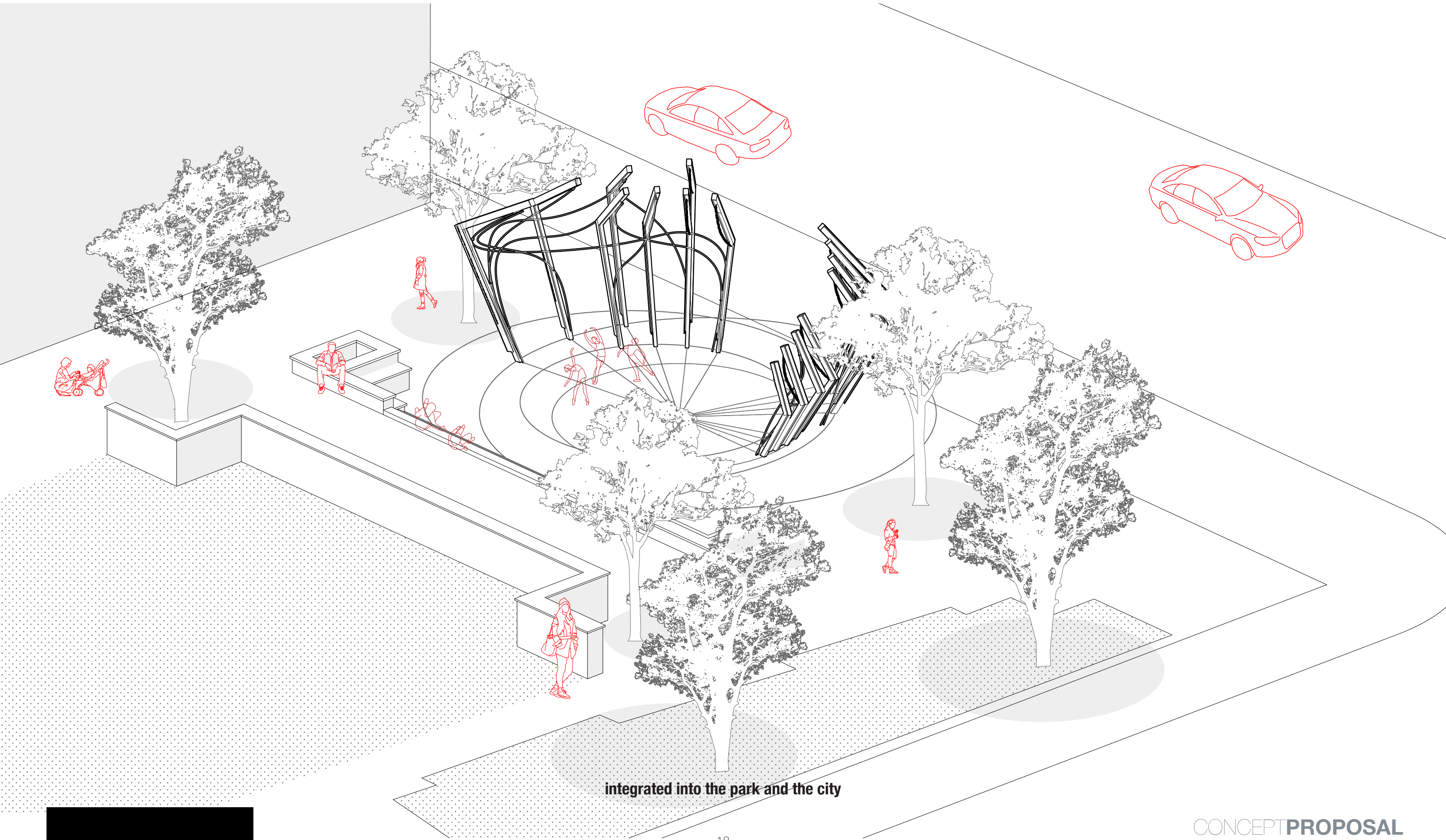

integrated into the park and the city



long life LED lights along markers give presence at night and reinforce form. lighting wired together in conduits underground. drivers in exterior rated underground vaults. lighting on astronomical clock timer



exterior grade, durable black locust wood at 2 sides of markers adding a natural texture. wood sealed with anti-graffiti coating

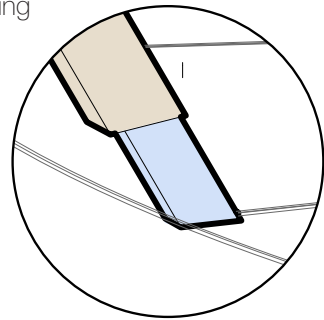

painted galvanized steel markers secured to concrete footings/pad with mechanical fasteners

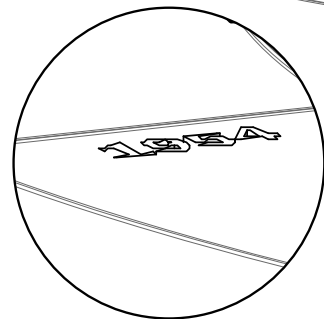

selected stainless steel dates embedded in concrete pavement



stainless steel lines at circles and radiating lines embedded in concrete pavement

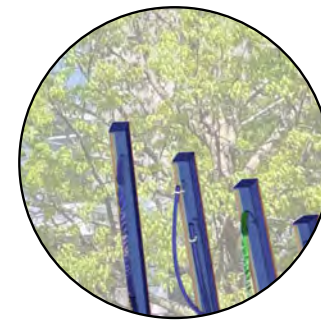

painted galvanized cap at steel tubes to keep out water

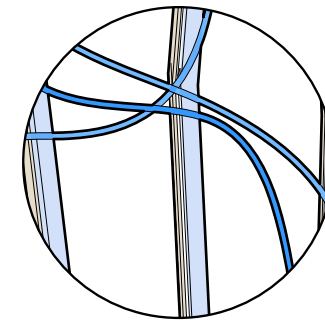

bent, painted galvanized steel pipes secured to steel



lengths of collectively created rope attached to markers

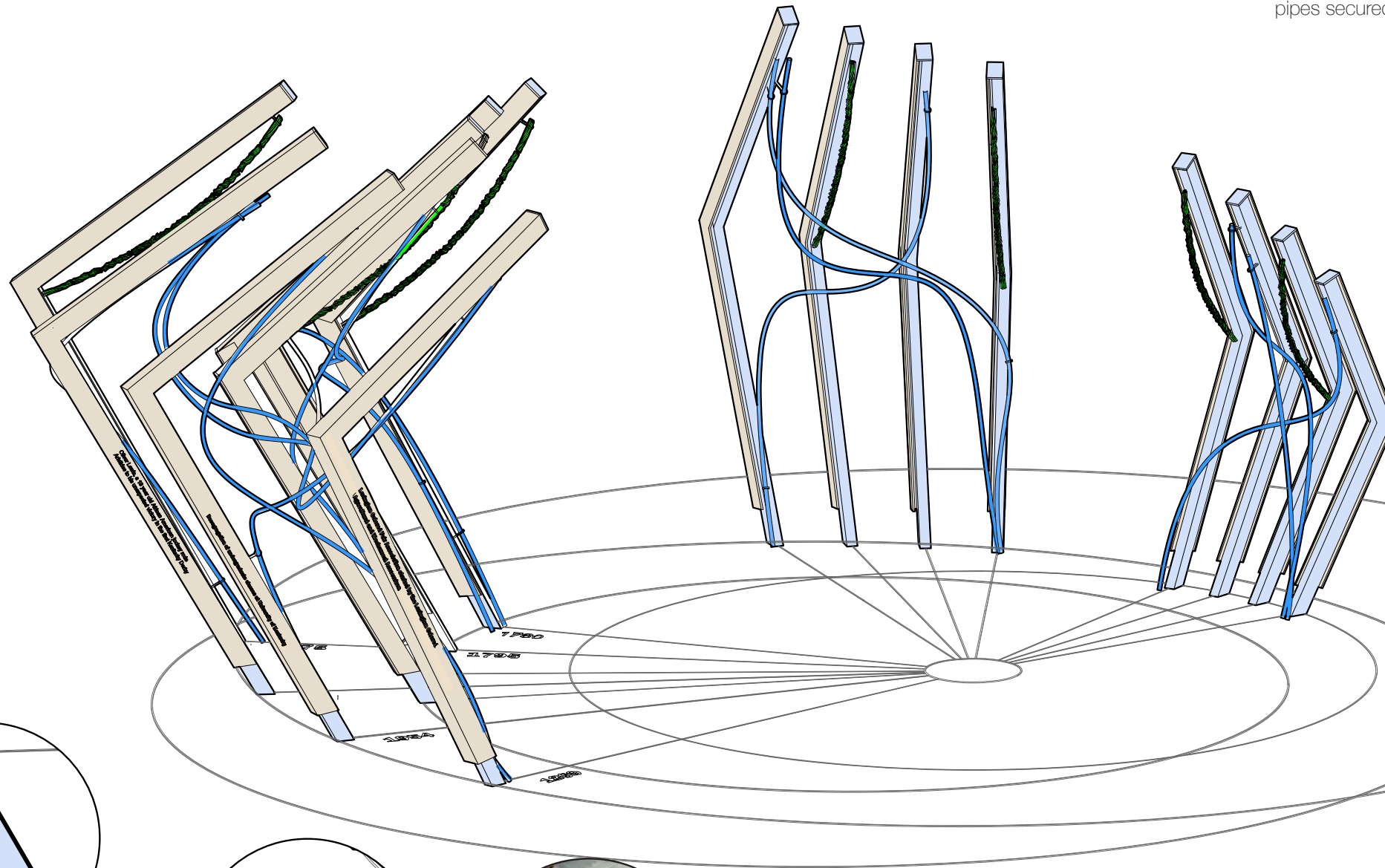

Steel

All steel will be galvanized and painted with a durable finish. Painted finish allows touchups as needed. Keep salt away from the base of the artwork when clearing snow. The tops of the main steel markers are closed to prevent water getting in from above. Weep holes will be provided in the base of the steel to release any moisture from condensation.

Wood

Black locust wood is a tough, rot-resistant, exterior grade wood grown in the United States with a life expectancy of 50 years.

LED lights

The expected lifespan of the LED lights is 15 years. The fixtures are accessible both at the markers and at the ground for replacement.

Rope

rPET rope is recycled PET rope which is durable and color stable. The braiding of the rope will make it even stronger.

General

An anti-graffiti coating will be applied to the entire artwork to resist minor to significant markings. The coating has a lifespan of 15 years and can be reapplied using a spray gun. The bent rods will be solid steel and secured to the main vertical markers and the horizontal crossing of the rods will happen above 10 feet to resist damage from grabbing. The artwork should be gently sprayed clean once a year to remove environmental debris.

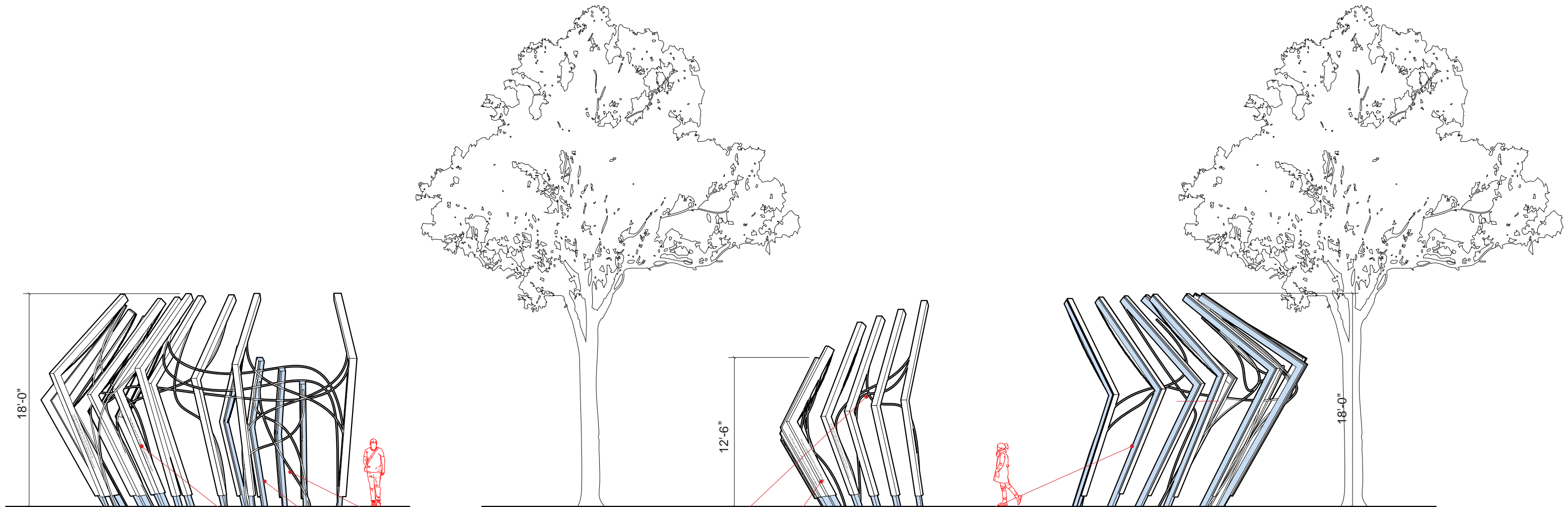

— painted galvanized steel rods anchored to steel markers.

— painted galvanized steel tube markers anchored to footings/pad below pavement

— black locust wood at two sides of steel marker with engraved historic text



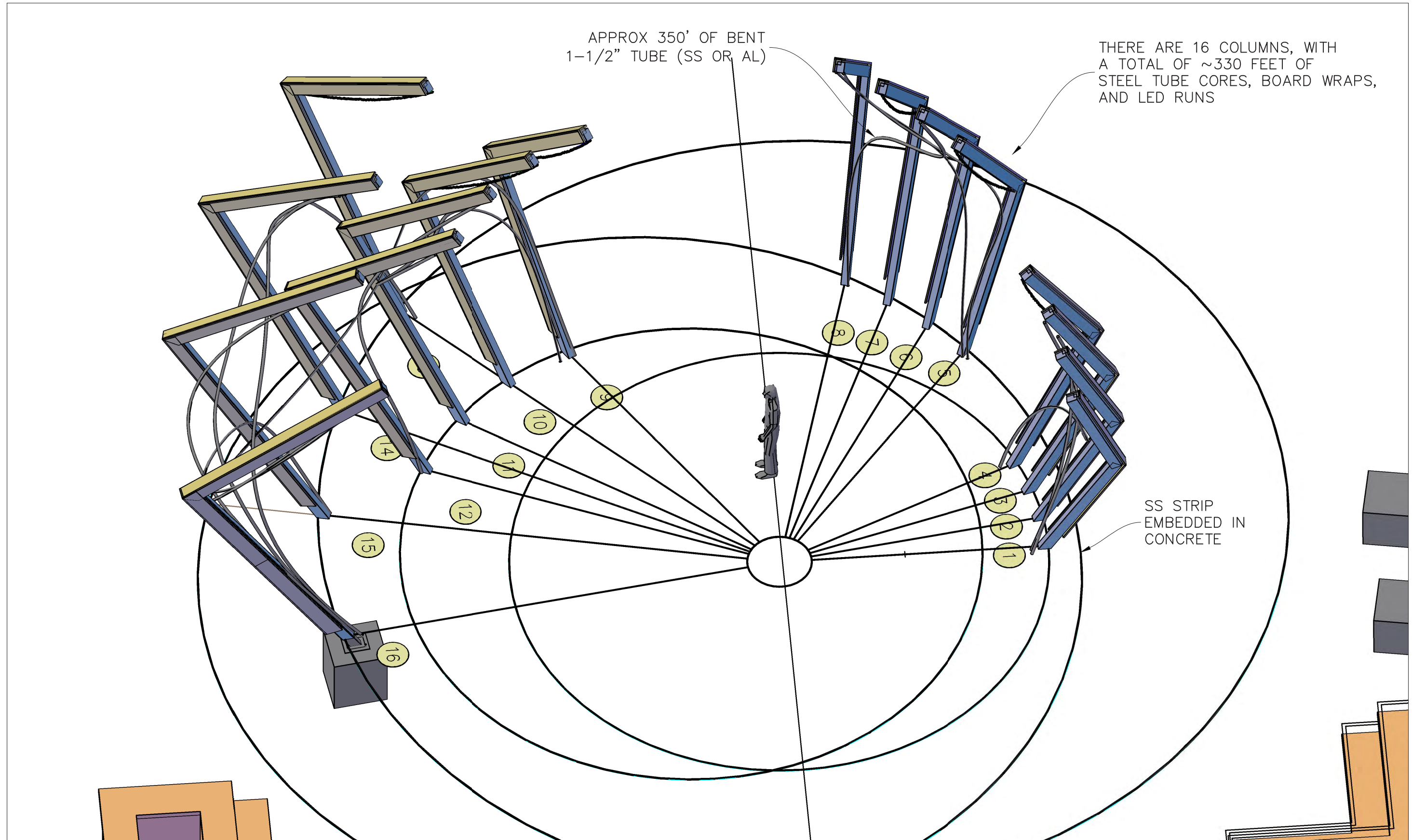

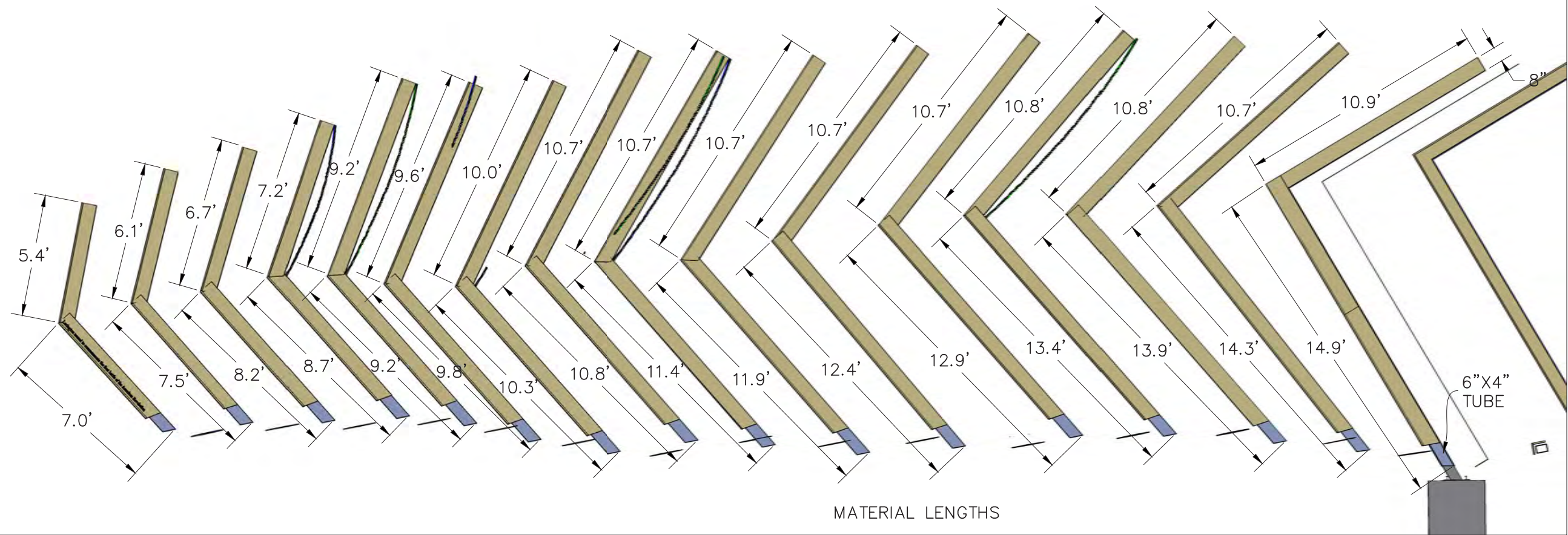
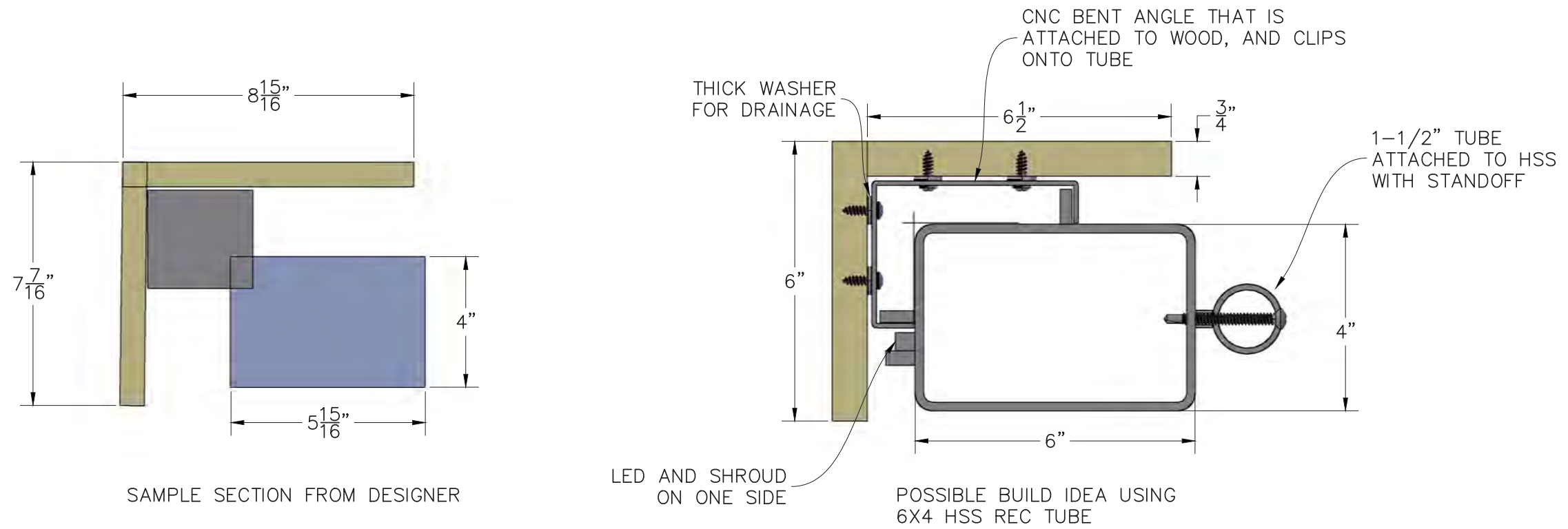

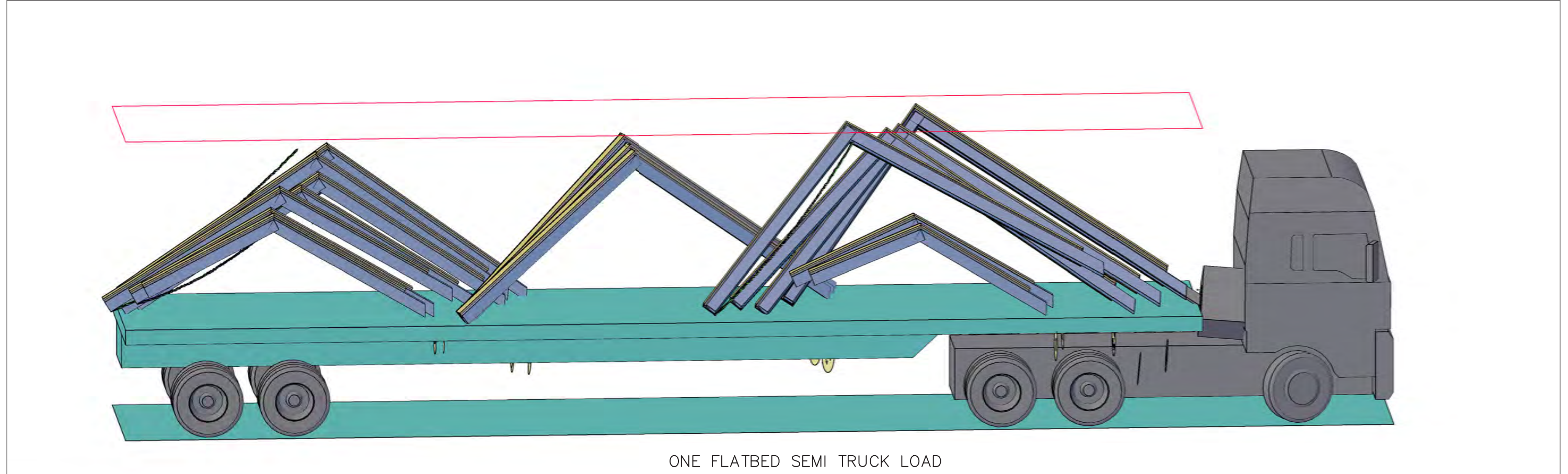
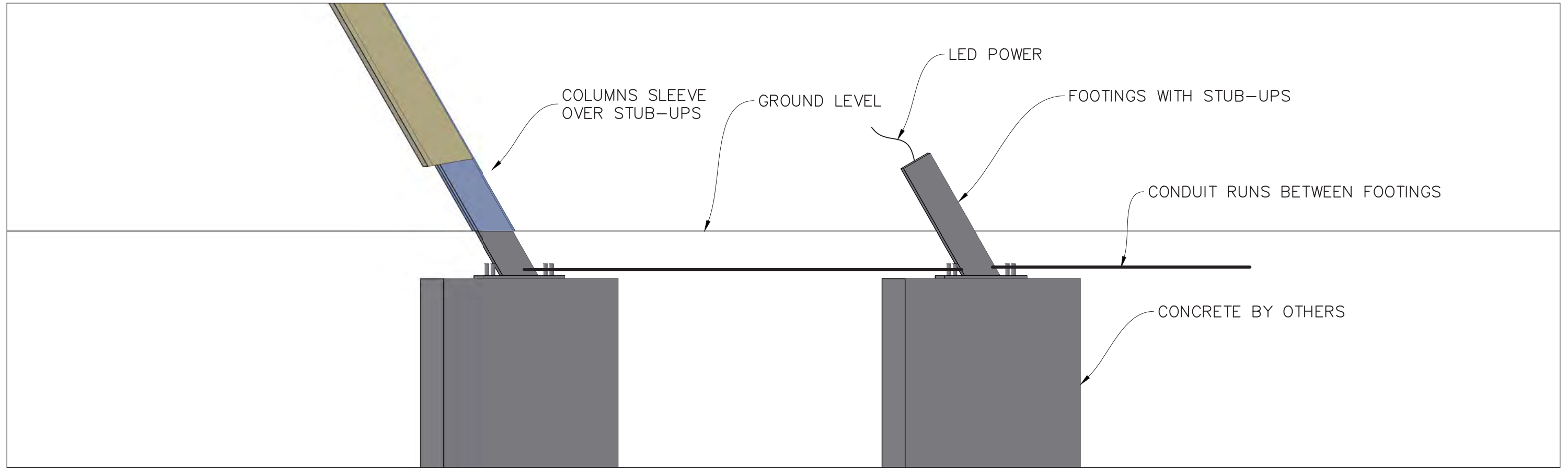







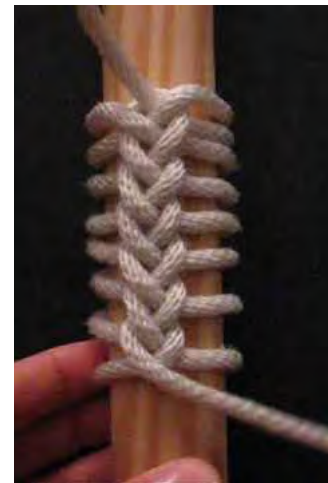























REMEMBER WHEN

histories recorded at rope weaving event accessible at website



BUILDING A SENSE OF PRIDE
LOCAL HISTORY + HERITAGE
 Listen to each story and be encouraged to foster a sense of community and connection as residents share their stories and experiences.

rope weaving community event similar to quilting circle

 00:00  01:18	 00:00  00:31	 00:00  01:25
 01 Community Story Alex Lawson	 02 Community Story Zaria Moon	 03 Community Story Miriam Serna
 00:00  00:58	 00:00  01:08	 00:00  00:29
 04 Community Story Angie Ruiz	 06 Community Story Shakira Lucas	 07 Community Story Canela Anderson
 00:00  01:15	 00:00  02:13	 00:00  01:40
 08 Community Story Hasir Colin Lawton	 09 Community Story Nefra Lawton	 07 Community Story Caroline James

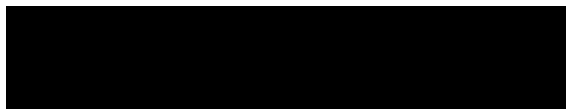

STEP FOUR
618: ASSEMBLE
SCULPTURE ON BASE
ADJUST LIGHTING,
TEST THOROUGHLY

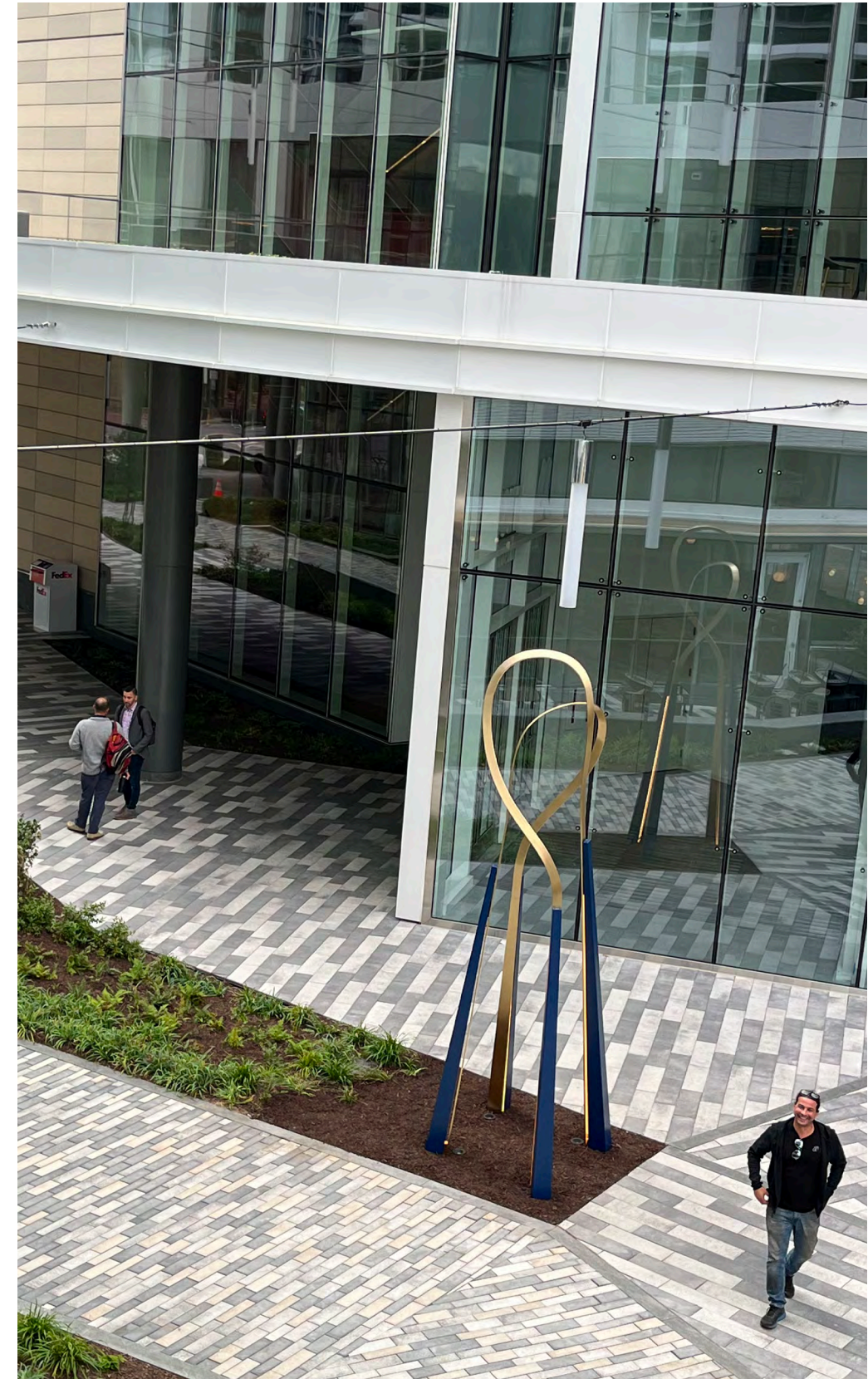
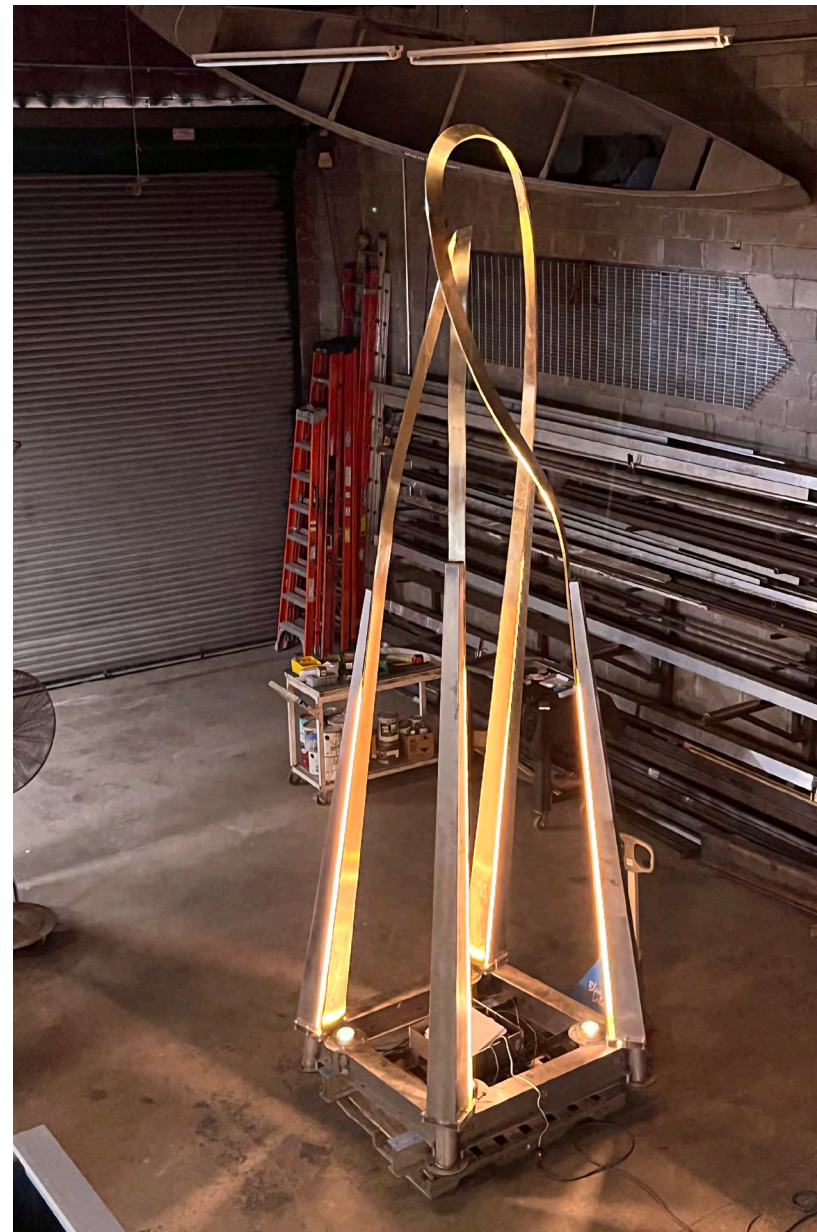
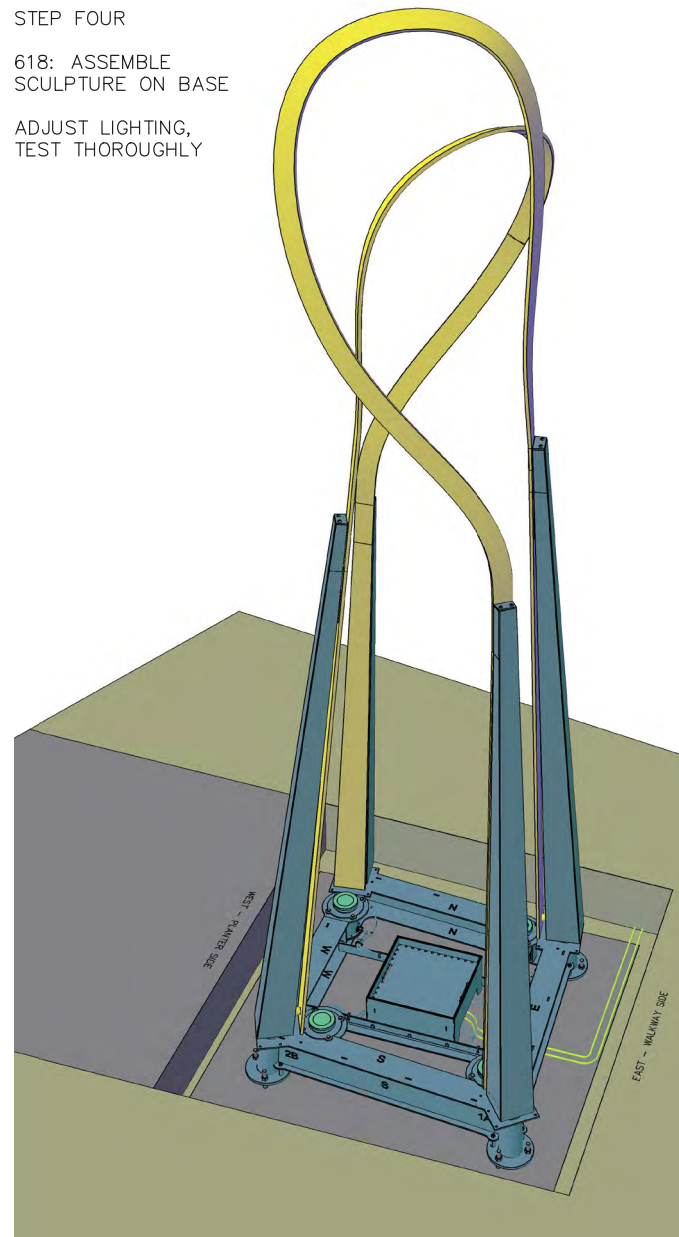

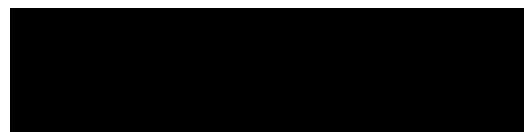
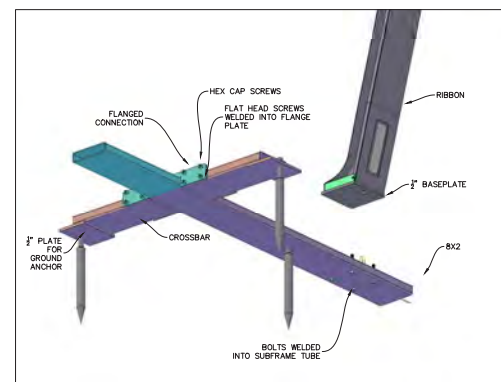
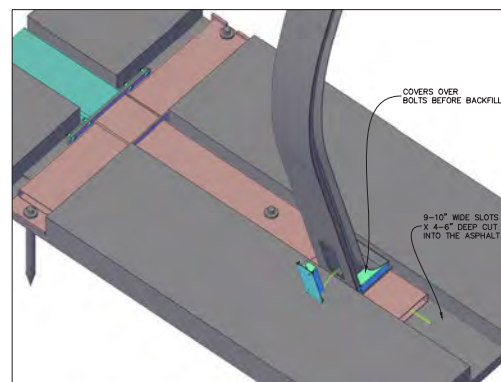
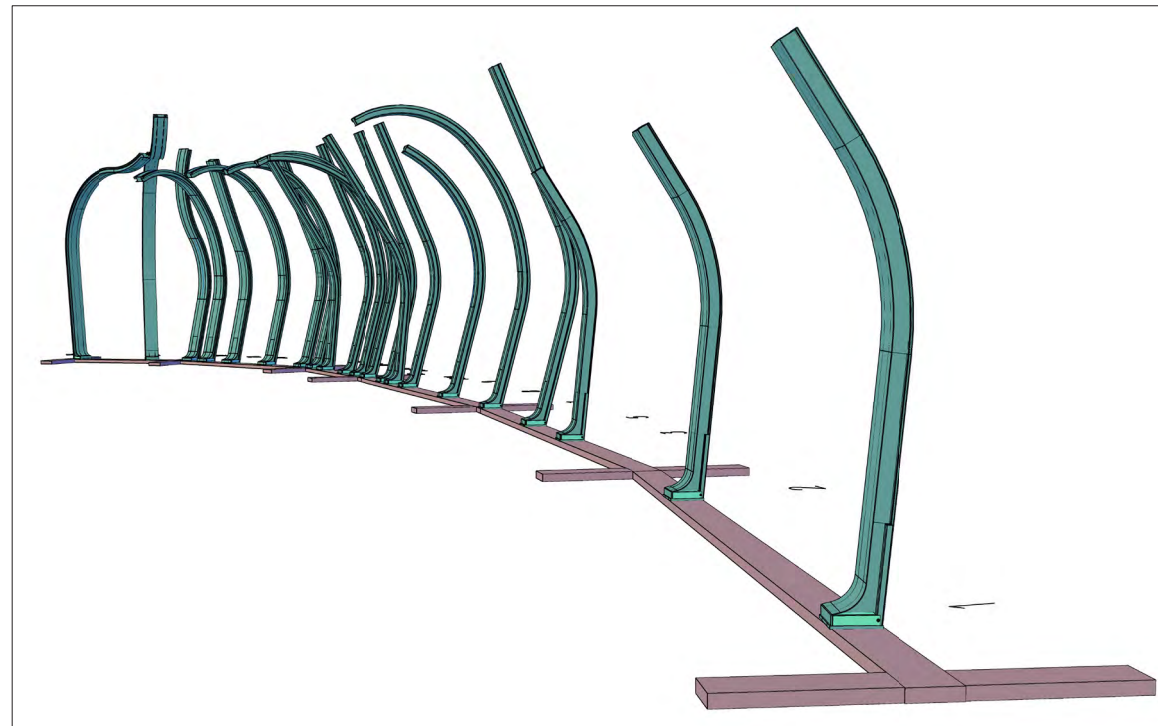
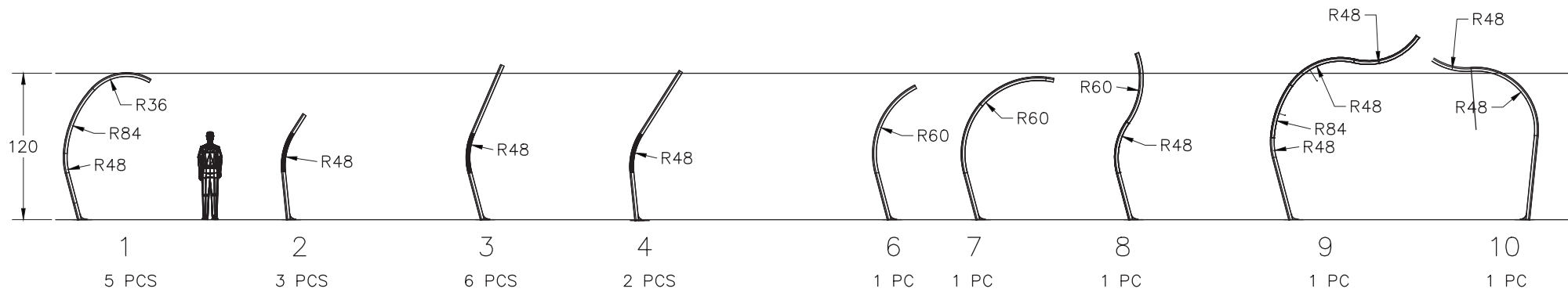

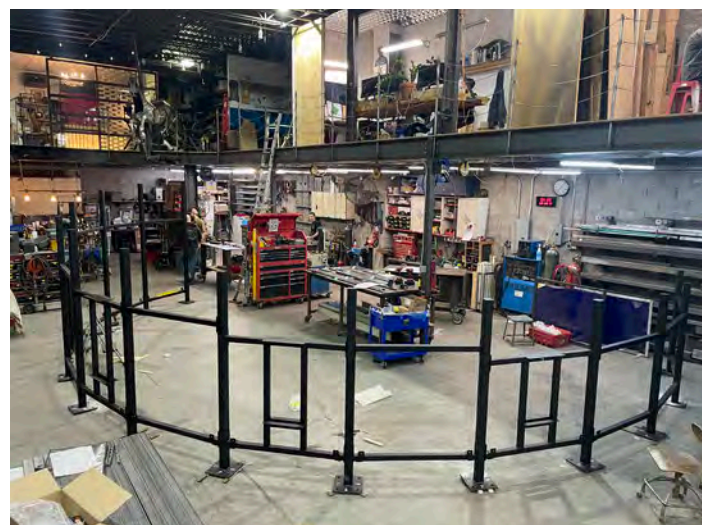
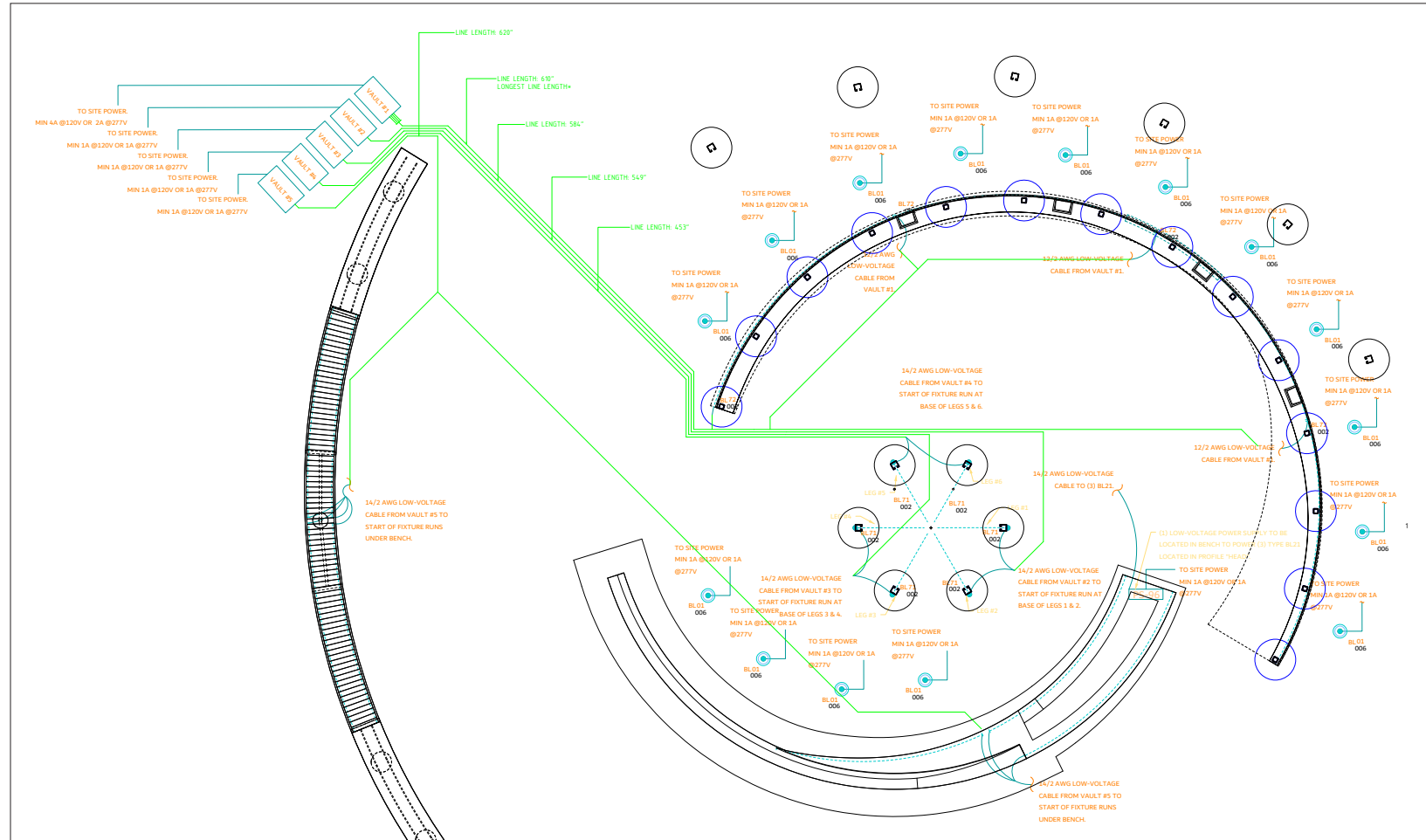

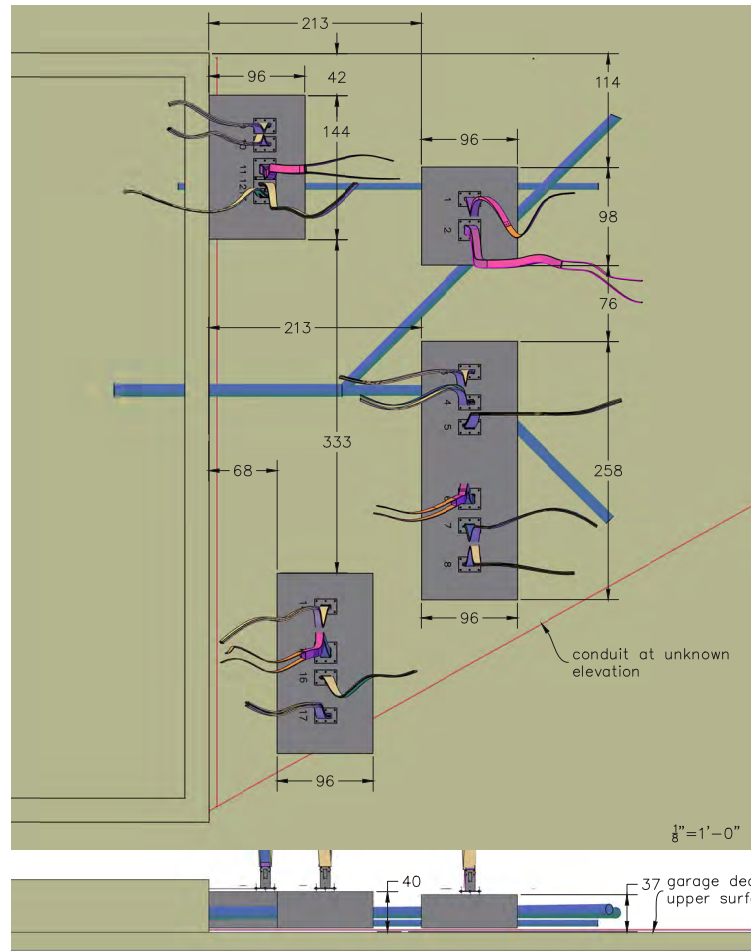

PLAN AND ELEVATION $\frac{1}{8}'' = 1'-0''$, ALL DIMS IN INCHES

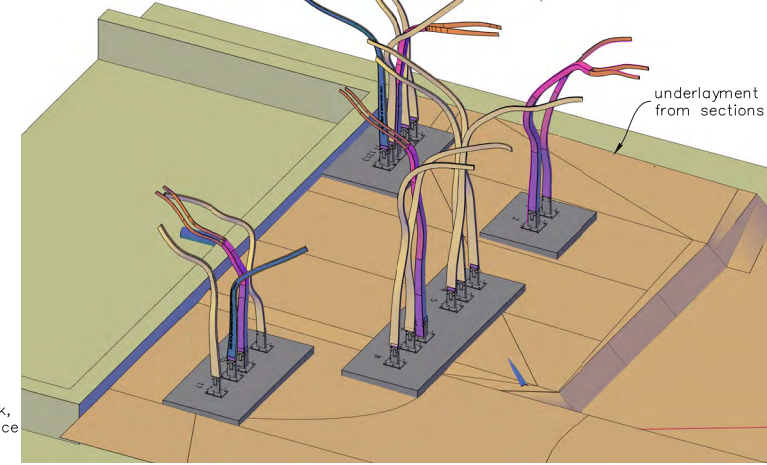
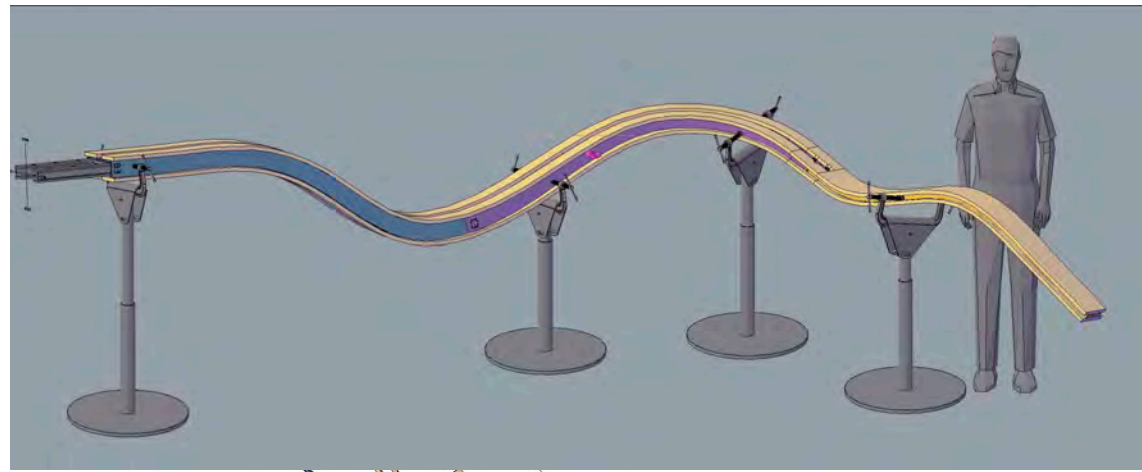

UCITY FOUNDATION SKETCH
BY QUILL HYDE FOR 618
9/26/23 PAGE 1

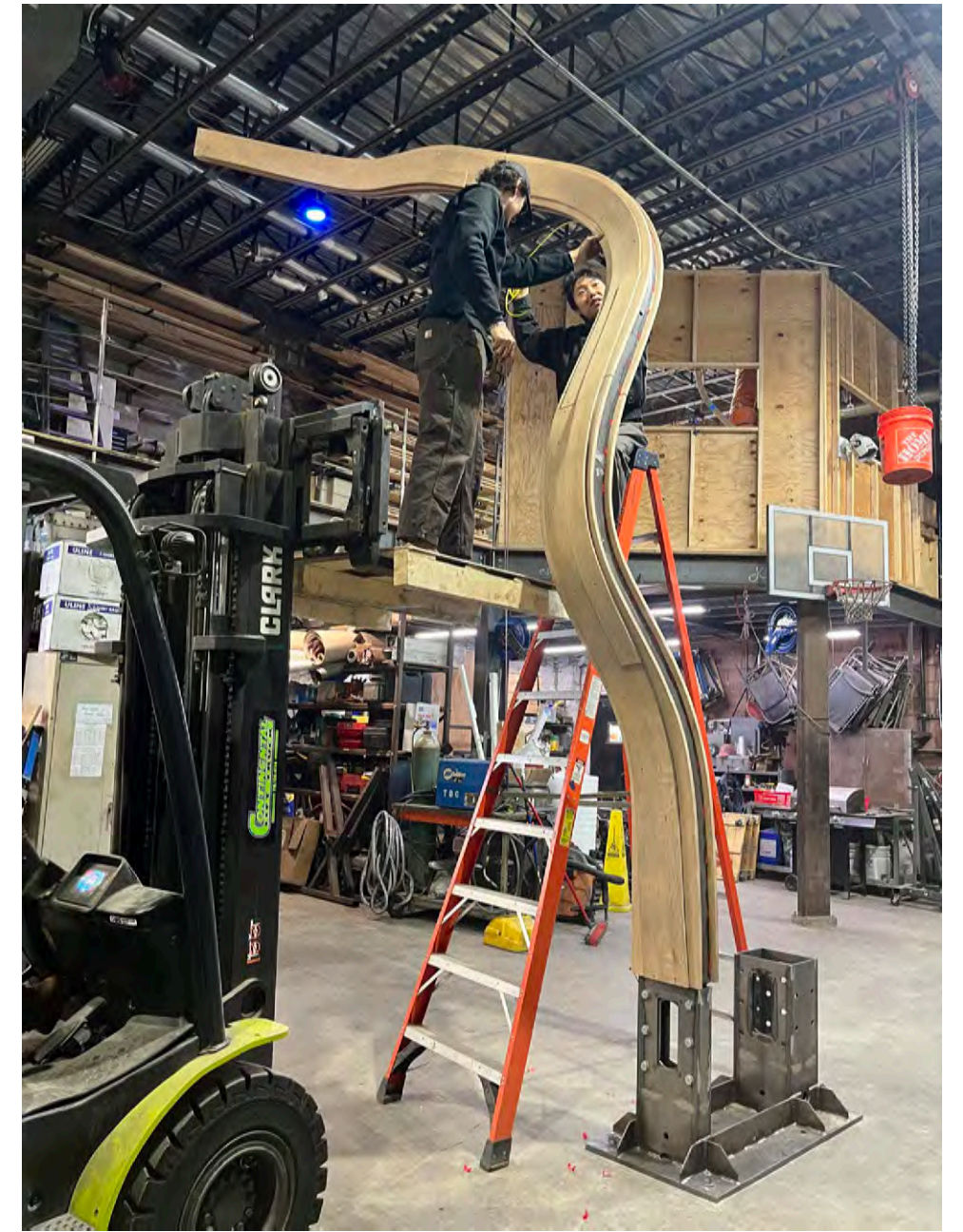
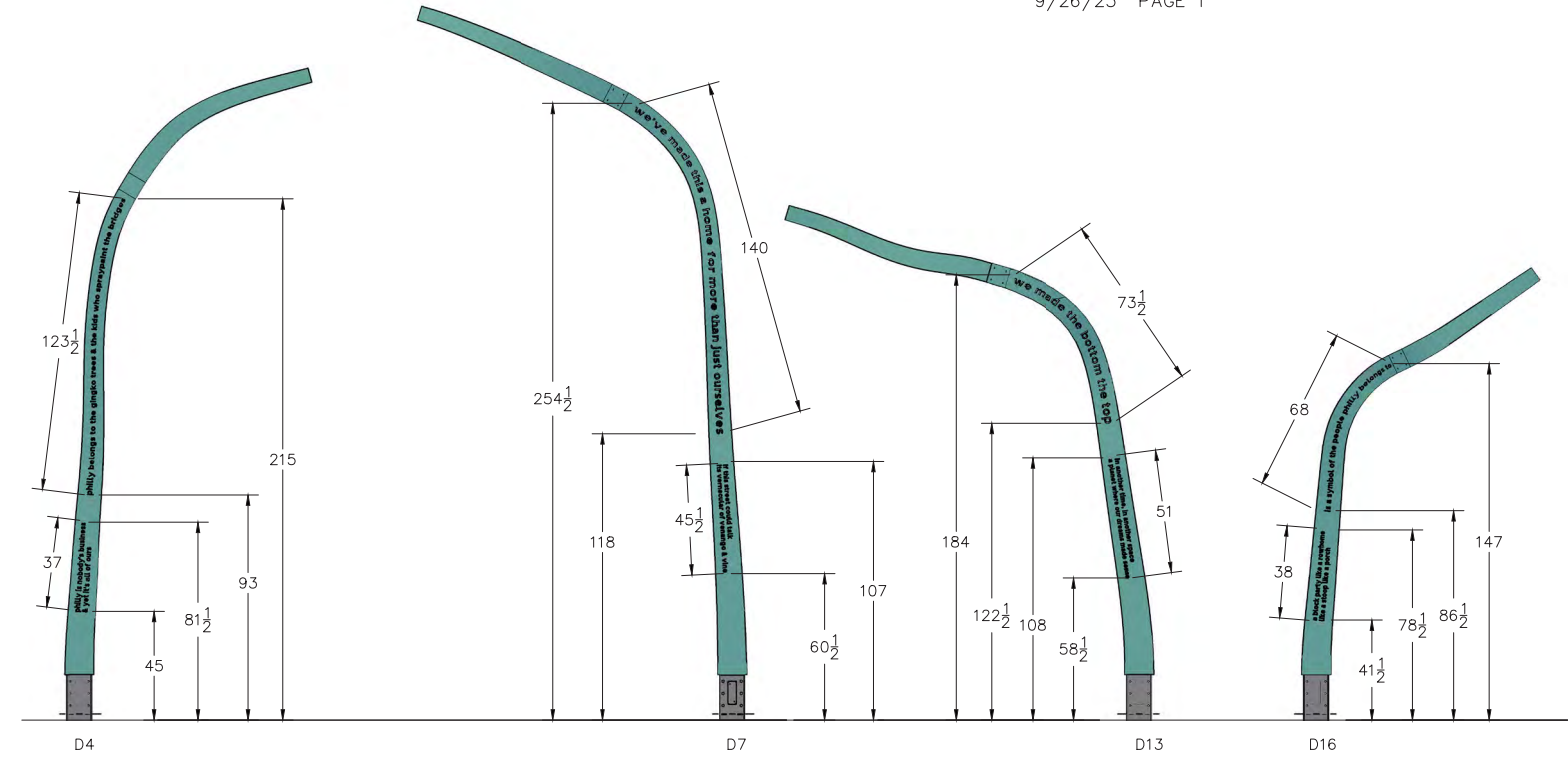

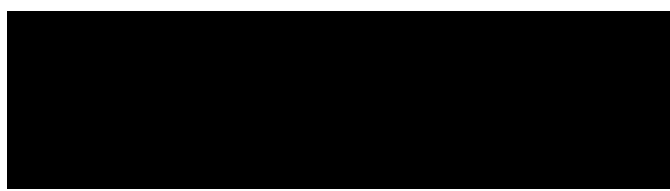
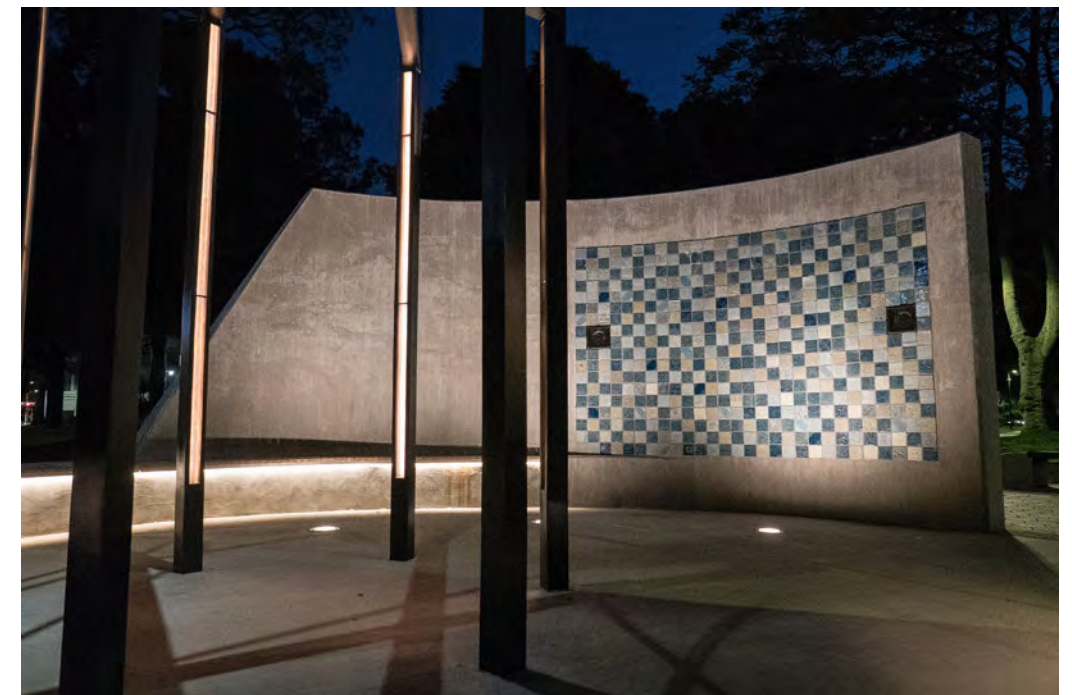
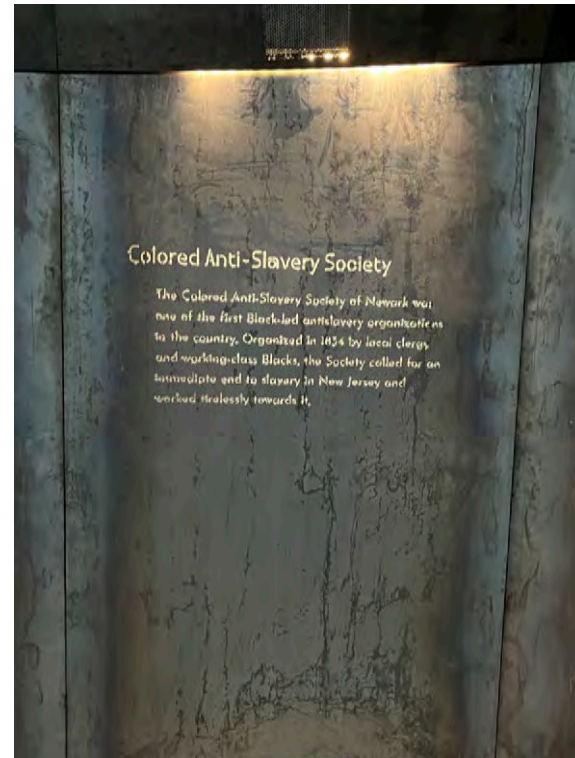

DESIGN PHASES	Key Personnel	Description	2024										2024				
			JUNE	JULY	AUG.	SEPT.	OCT.	NOV.	DEC.	JAN.	FEB.	MAR.	APR.	MAY	JUNE	JULY	AUG.
Contract Finalized	Client, SCJ																
Finalize Concept	Client, SCJ	design updates															
Design Development part 1	SCJ, Client, Fabricator	coordinate site services, refine budget, finalize fabricator															
Design Development part 2	SCJ, Fabricator	update fabrication design															
Community Engagement Coordination	SCJ, Client	coordination with community stakeholders, finalize community engagement activities															
Community Making Sessions	SCJ, Client																
Audio Editing	SCJ, Audio Consultant	collect audio and edit as needed															
Website development	SCJ, Web developer	develop website interface and graphics															
Engineering	SCJ, Fabricator, structural engineer	detailing of installation forms, structural stability and constructability															
Construction Documents	SCJ, Fabricator, structural engineer	final drawings of installation details for construction															
Shop Drawings	SCJ, Fabricator	shop drawing production and review + mockups															
Fabrication	Fabricator	fabrication of installation parts															
Site Preparation - Part 1	SCJ, Client, Site Contractor	contractor preparation of sitework related to foundation and conduits/power															
Installation - Part 1	SCJ, Fabricator, Sitework contractor	fabricator installation of foundation attachments and wiring (all below surface work)															
Site Preparation - Part 2	SCJ, Client, Site Contractor	contractor final site preparation work															
Installation - Part 2	SCJ, Fabricator, Sitework contractor	Delivery and final installation of all parts of artwork															INSTALL

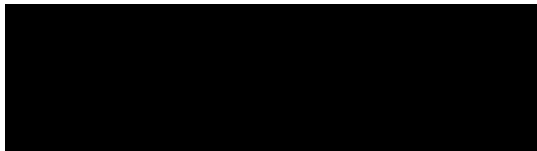

Category	Details	Amount (\$)
Artist Fee		
		\$150,000
Subtotal ARTIST FEE		\$150,000
INSTALLATION CONSTRUCTION		
General Expenses		\$65,000
	Engineering	\$15,000
	Construction Documents/Shop Drawings/Mockups	\$35,000
	Documentation (photography, video)	\$15,000
Fabrication & Installation		\$415,000
	Steel, wood and stainless inlay fabrication	\$335,000
	Lighting	\$30,000
	Rigging/Shipping/Installation	\$50,000
Subtotal CONSTRUCTION BUDGET		\$480,000
COMMUNITY ENGAGEMENT		
Rope making sessions		\$45,000
2 - 3 medium sized	Staff - curation, coordination, event staff	\$10,000
	Sound recording equipment	\$2,500
	Audio Tech	\$5,000
	Activity supplies and rentals	\$20,000
	Website development	\$7,500
Subtotal Community Workshops Budget		\$45,000
Contingency @ 10%		\$75,000
TOTAL BUDGET		\$750,000